

ELENZIO 3S

Montageanleitung / Notice de Montage / Assembling Instruction

ART. NR: 13 087 110

EAN: 40 10 340 18 71 14

ORDER : 18397

DE: Wichtige Montage – Tipps hier zum herunterladen:

EN: Important assembling suggestions download:

FR: Conseils de montage importants à télécharger ici :

BG: Важни съвети за сглобяване, които да изтеглите от тук:

CZ: Důležité montážní tipy ke stažení zde:

EE: Olulised kokkupanemisetepanekute allalaadimine:

DK: Vigtige montage tips til at downloade:

ES: Descarga de sugerencias de montaje importantes:

FI: Tärkeät kokoamisedotukset ladataan:

GR: Λήψη σημαντικών προτάσεων συναρμολόγησης:

HR: Preuzimanje važnih prijedloga za sastavljanje:

HU: Fontos összeszerelési javaslatok letöltése:

IT: Download importanti suggerimenti di montaggio:

LT: Svarbūs surinkimo pasiūlymai atsisiųsti:

LU: Wichtig Versammlungsvirschléi eroflueden:

LV: Svarīgu montāžas ieteikumu lejupielāde:

NL: Belangrijke montagesuggesties downloaden:

NO: Viktige nedlastingsforslag:

PL: Pobieranie ważnych sugestii montażowych:

PT: Download de sugestões importantes de montagem:

RO: Descărcare de sugestii importante de asamblare:

RS: Преузимање важних предлога за састављање:

RU: Важные предложения по сборке скачать,:

SL: Prenos pomembnih predlogov za sestavljanje:

SE: Viktiga hämtningsförslag:

SK: Stiahnutie dôležitých návrhov na zostavenie:

TR: Önemli montaj önerileri indir:

ARB: المهمة التجميع اقتراحات تنزيل:



Z. A. du Niederwald

F-67470 Seltz

www.interlink-sas.com



Colli 1/1		
B	412x400	1x
C	689x378	1x
D	689x378	1x
F	374x96	1x
G	615x390	1x
H	374x96	1x
M	347x358	3x
R	350x111	6x
S	317x109	3x
T	387x202	3x

Colli 1/1		
1	400x103x2,5	2x
2	733x103x2,5	2x

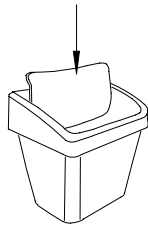

ELENZIO 3S

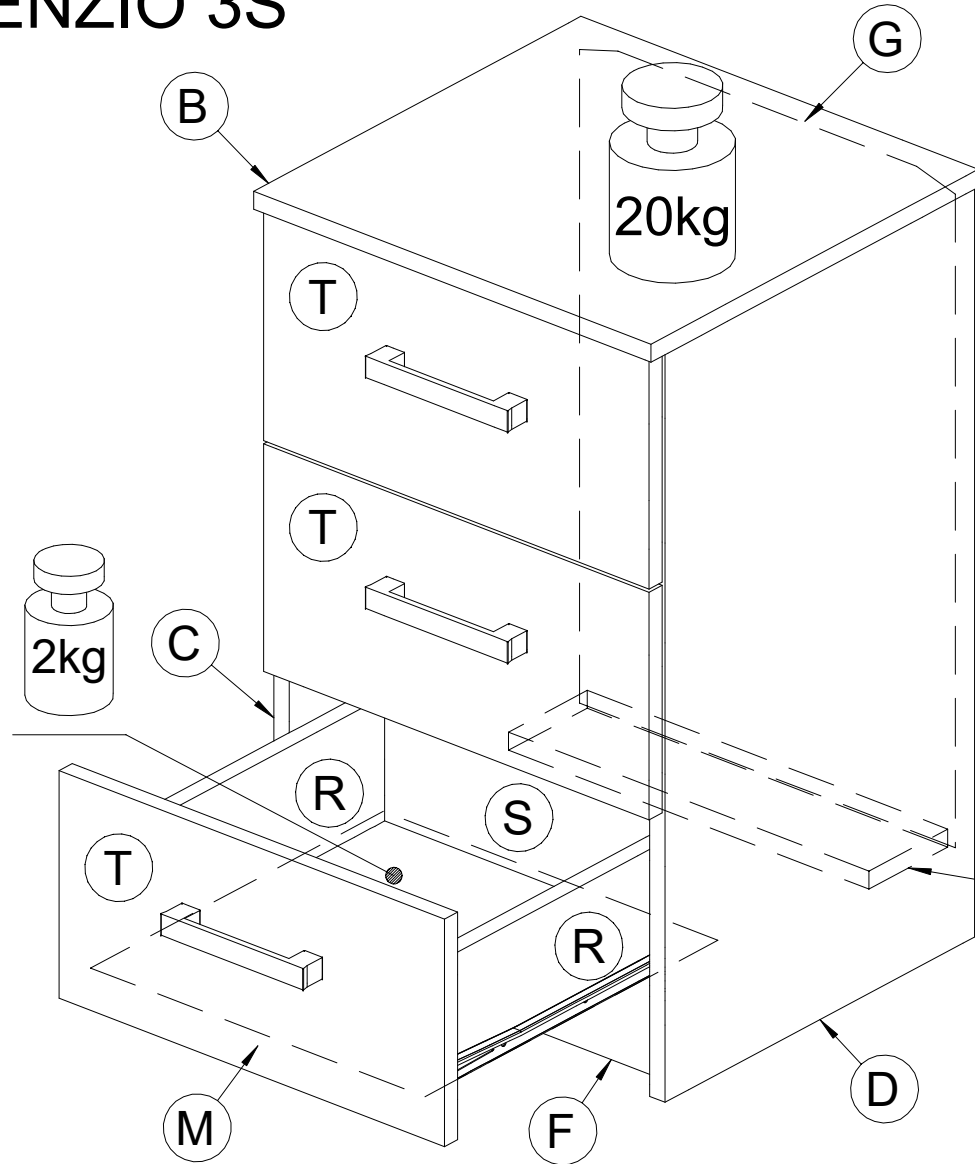

1/21

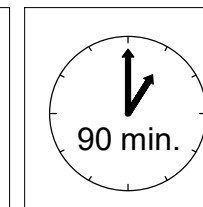
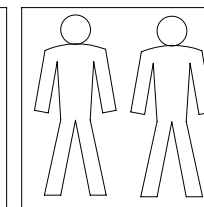
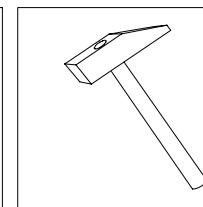
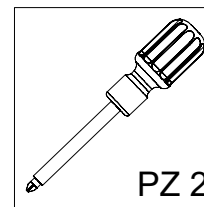
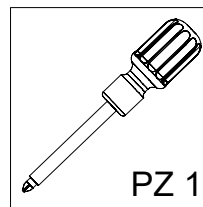
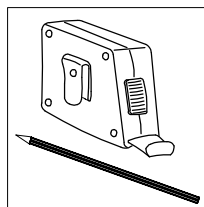
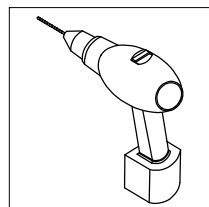
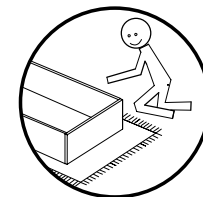
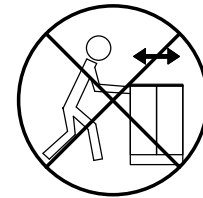
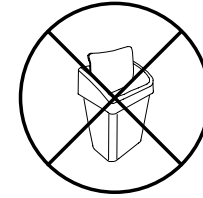
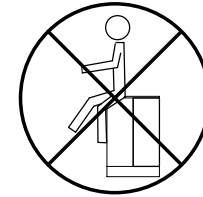

Z1		18x
Z2		1x
Z3		6x
Z16		18x
Z29		12x
Z30		22x
Z33		22x
Z58		6x
Z67		3x
Z68		12x
Z90		4x
Z114		6x
Z156		11x
Z178		12x
Z166		3x
Z269		3x

Z16		4x
Z75		2x
Z81		2x
Z140		2x

2.

B 412x400 1x

Z33		4x
-----	--	----

3.

F 374x96 1x

H 374x96 1x

Z1		2x
Z30		6x

4.

C 689x378 1x

Z30		2x	Z90		2x
Z114		3x	Z68		6x
Z1		2x	Z67		3x
Z33		3x	Z114		3x

5.

D 689x378 1x

Z30		2x	Z90		2x
Z114		3x	Z68		6x
Z1		2x	Z67		3x
Z33		3x	Z114		3x

6.

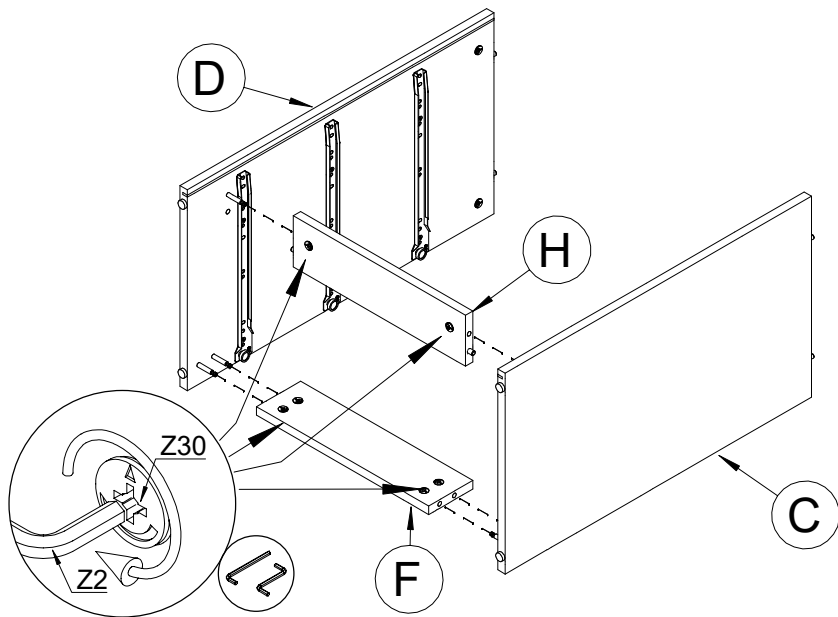

7.

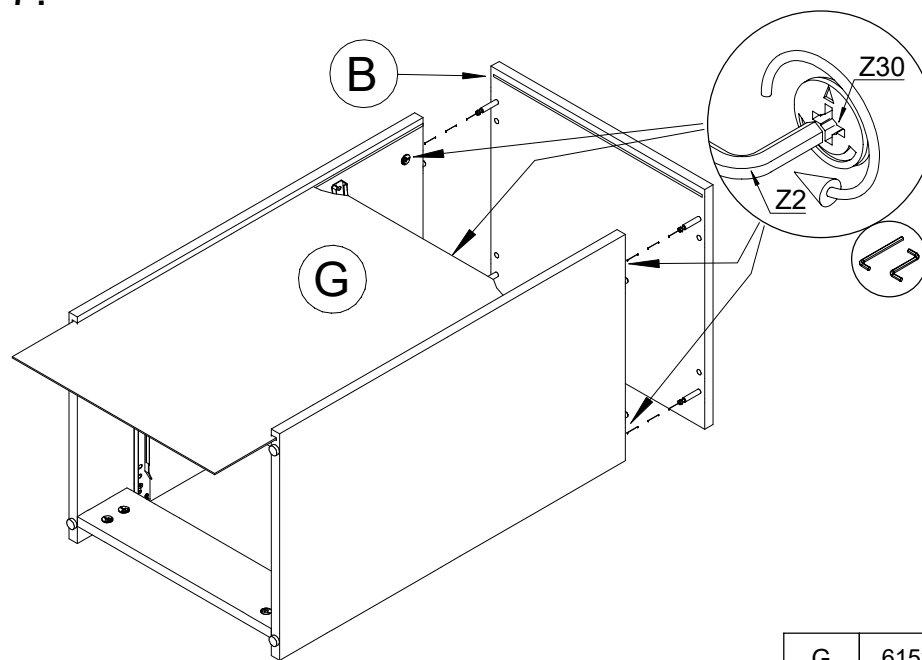

G	615x390	1x
---	---------	----

8.

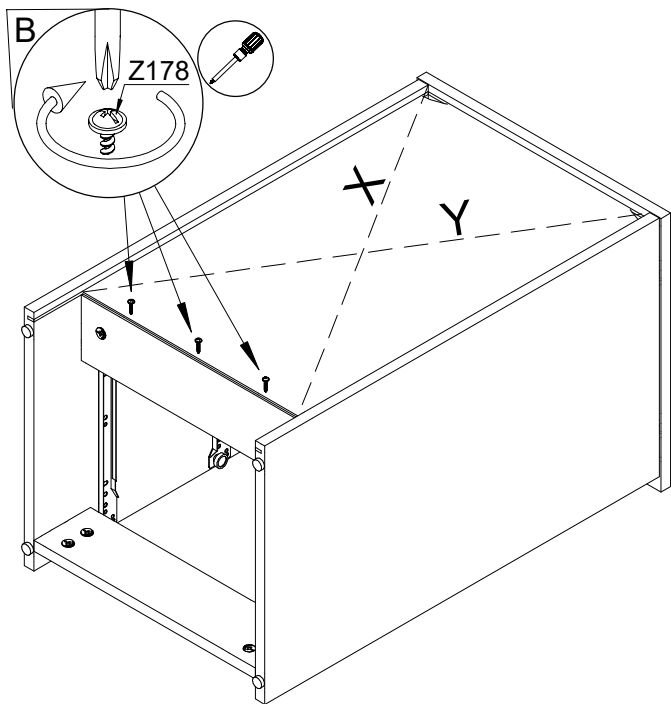

A

$X = Y$

Z178		Ø3x20	3x
------	--	-------	----

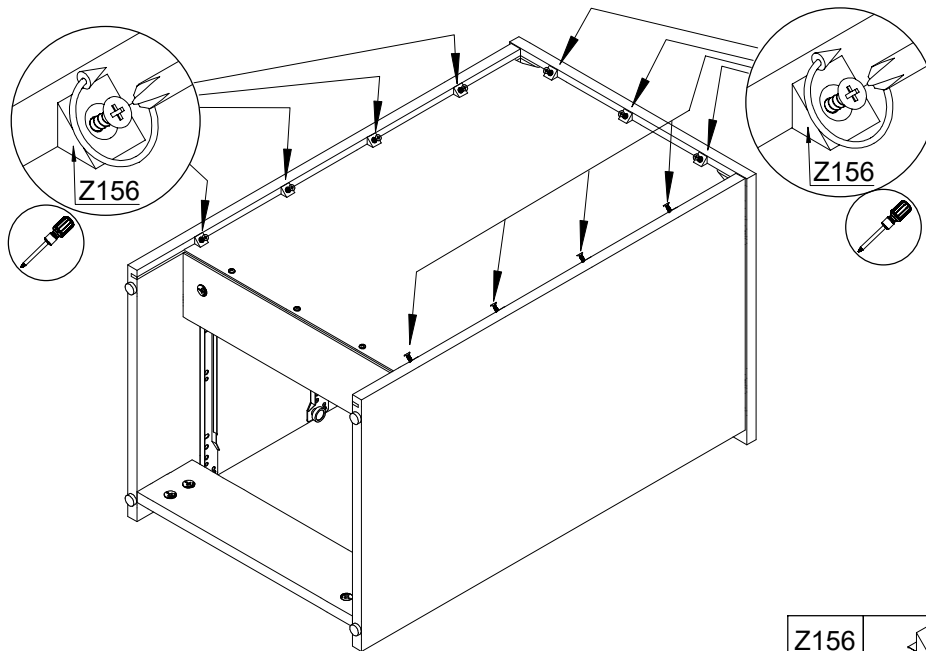

9.

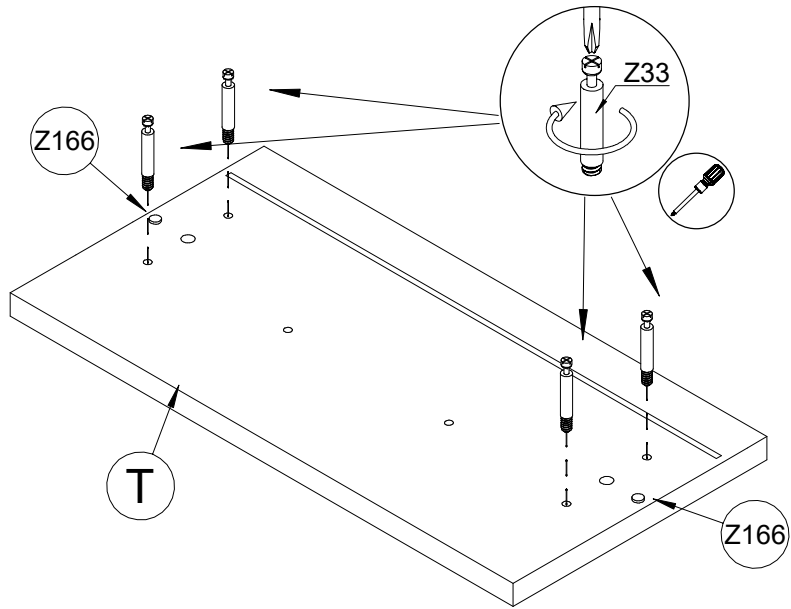

Z156		11x
------	---	-----

10.



Z33		12x
Z166		3x

T	387x202	3x
---	---------	----

11.

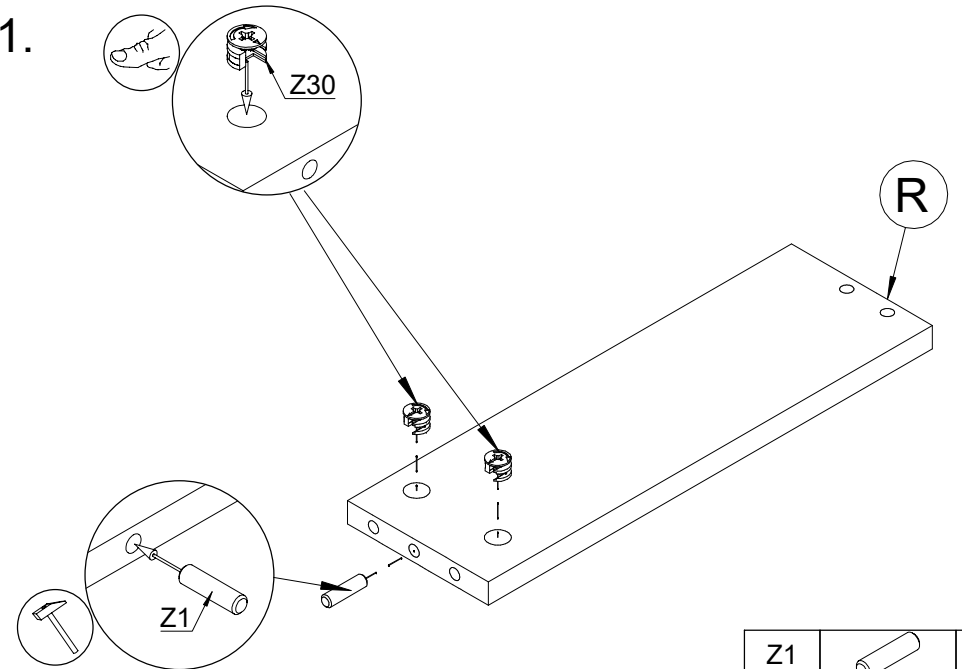

Z1		6x
Z30		12x

R	350x111	6x
---	---------	----

12.

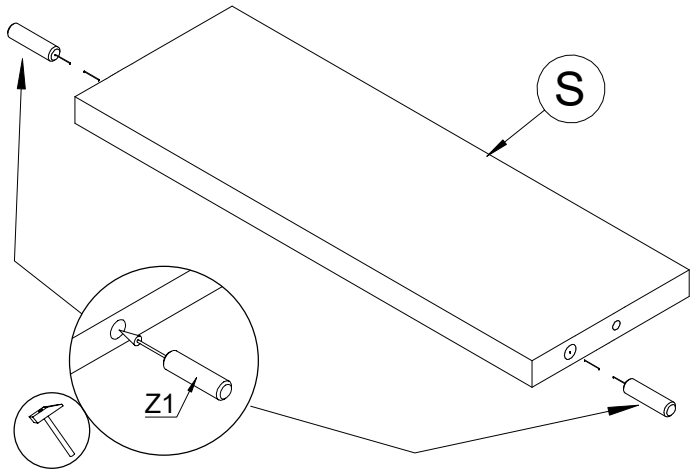

Z1		6x
----	--	----

S	317x109	3x
---	---------	----

13.

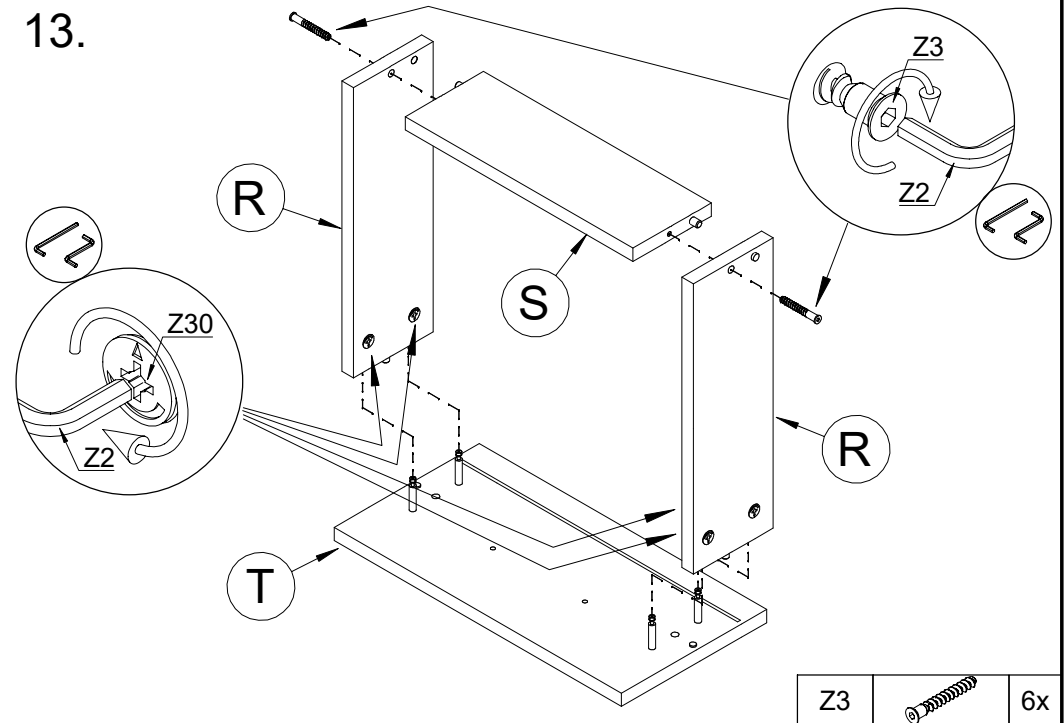

Z3		6x
----	---	----

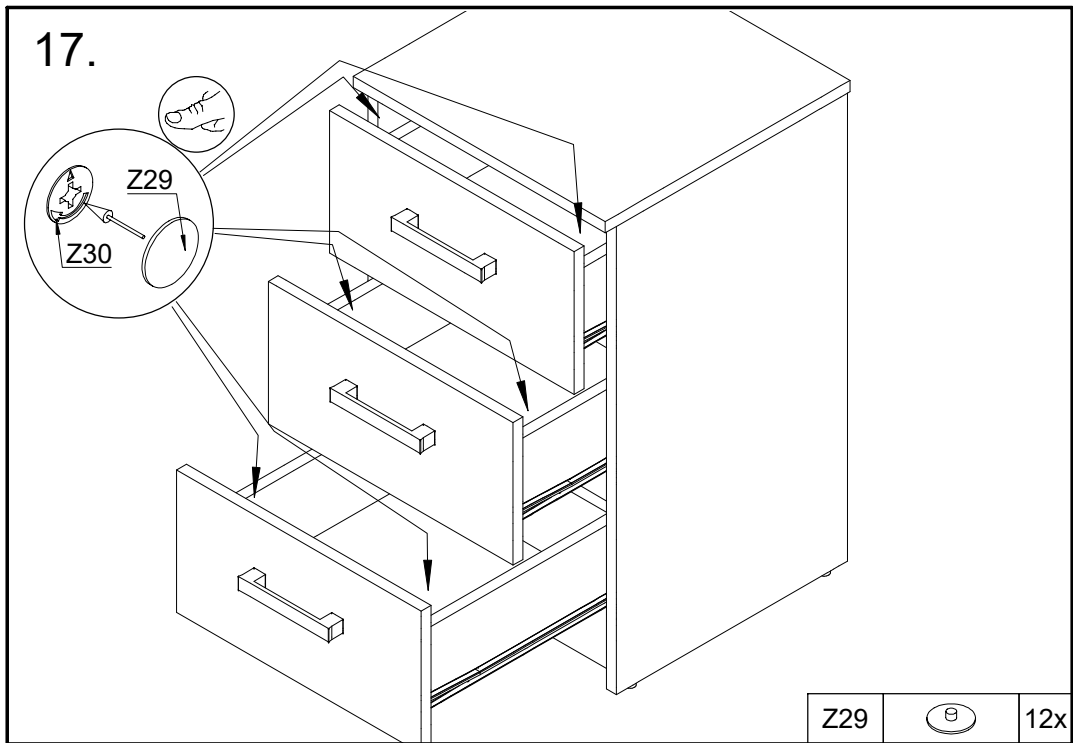
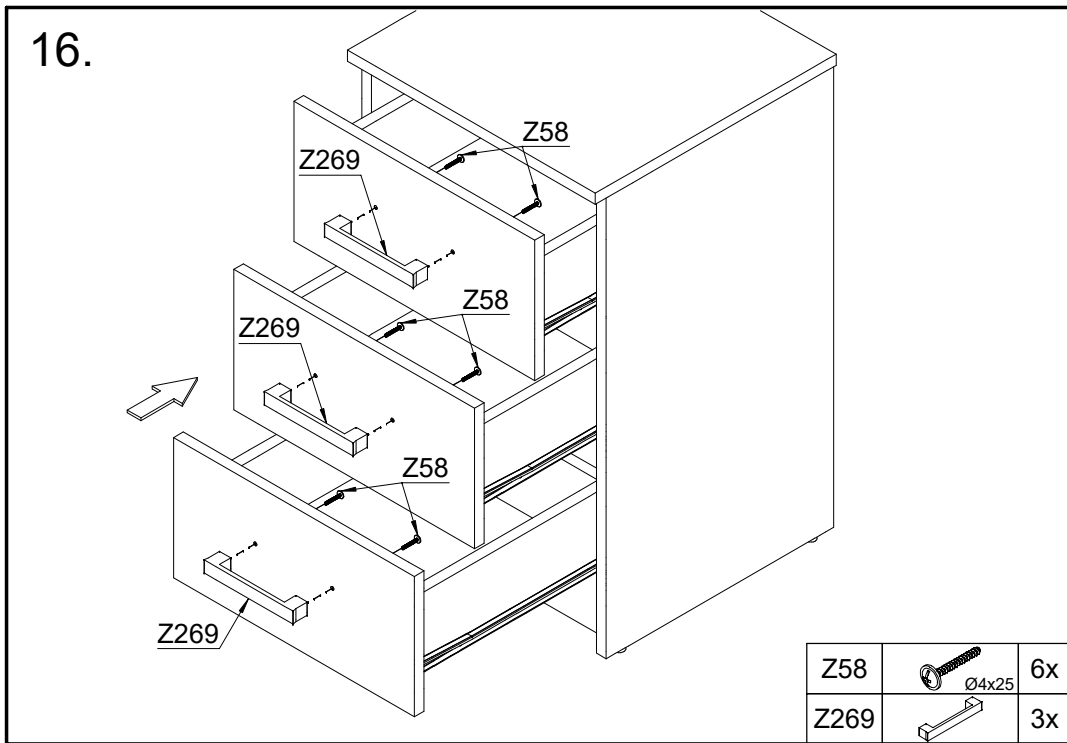
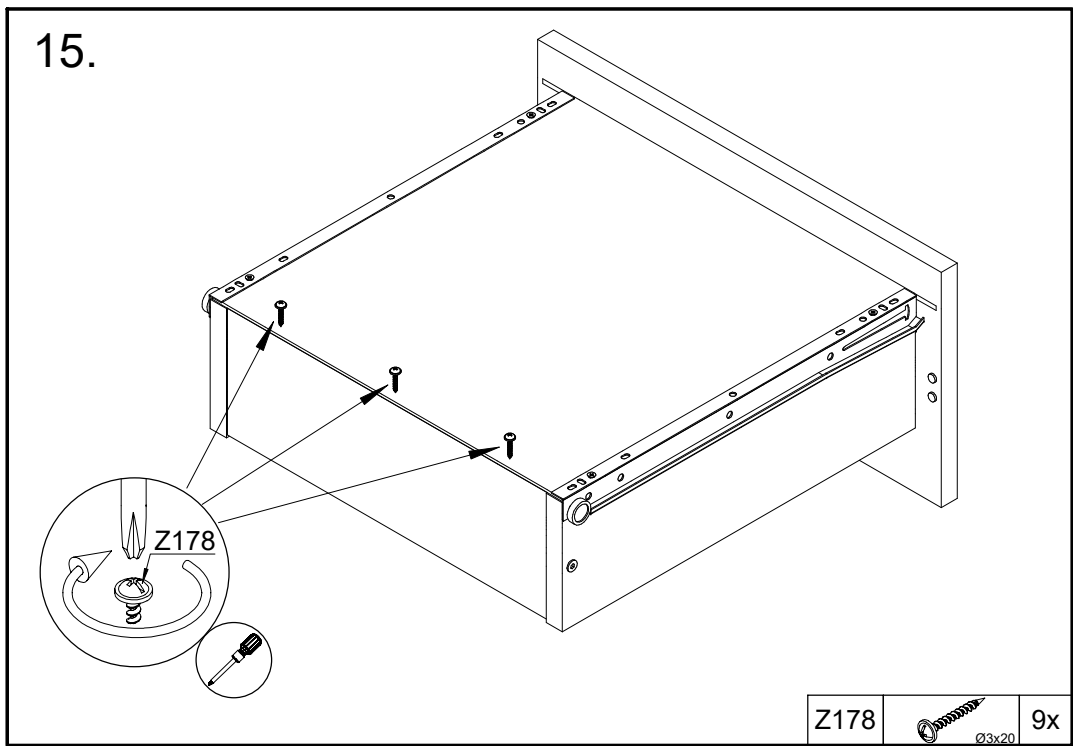
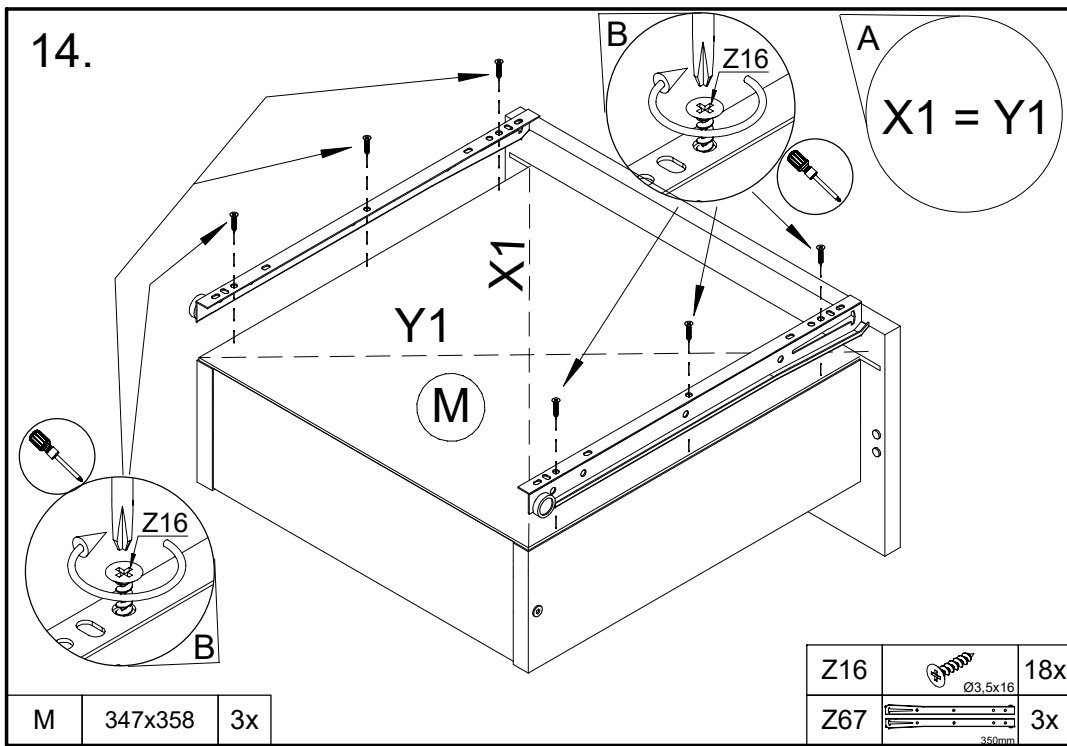

18.

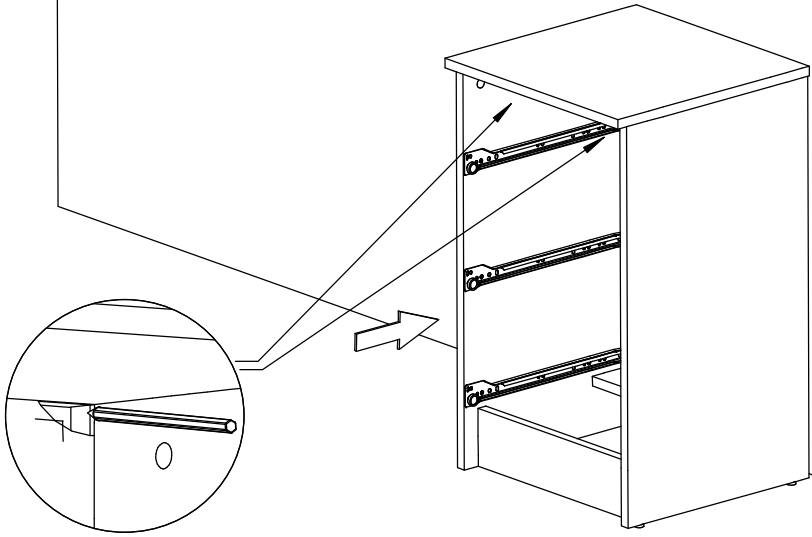

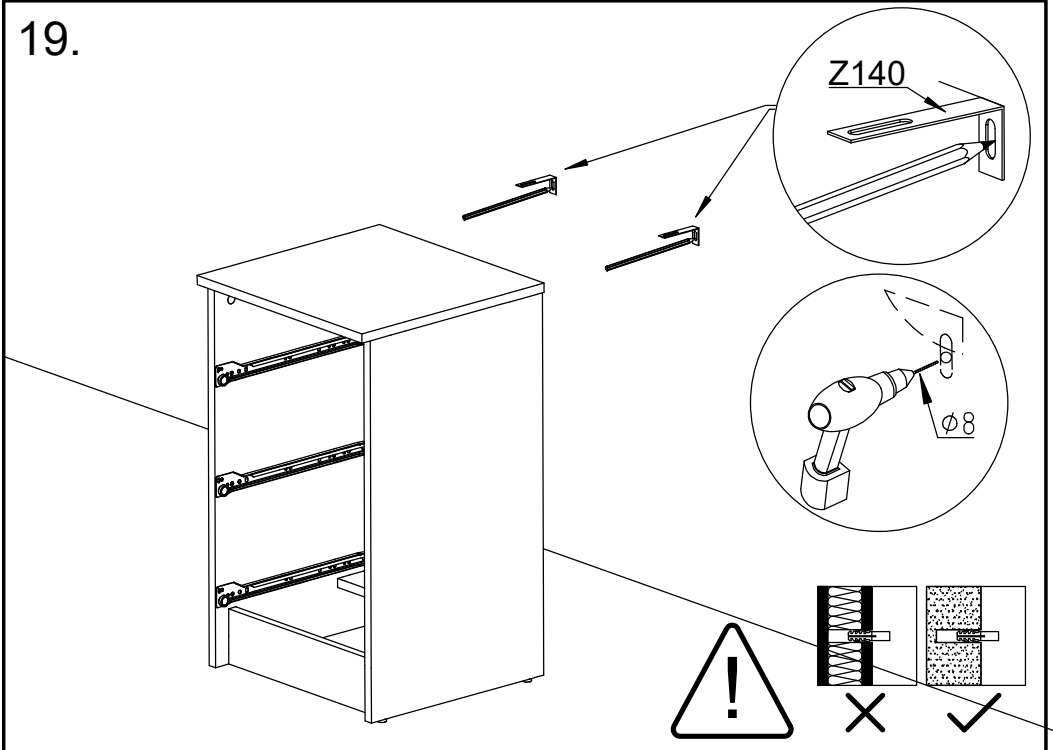

19.



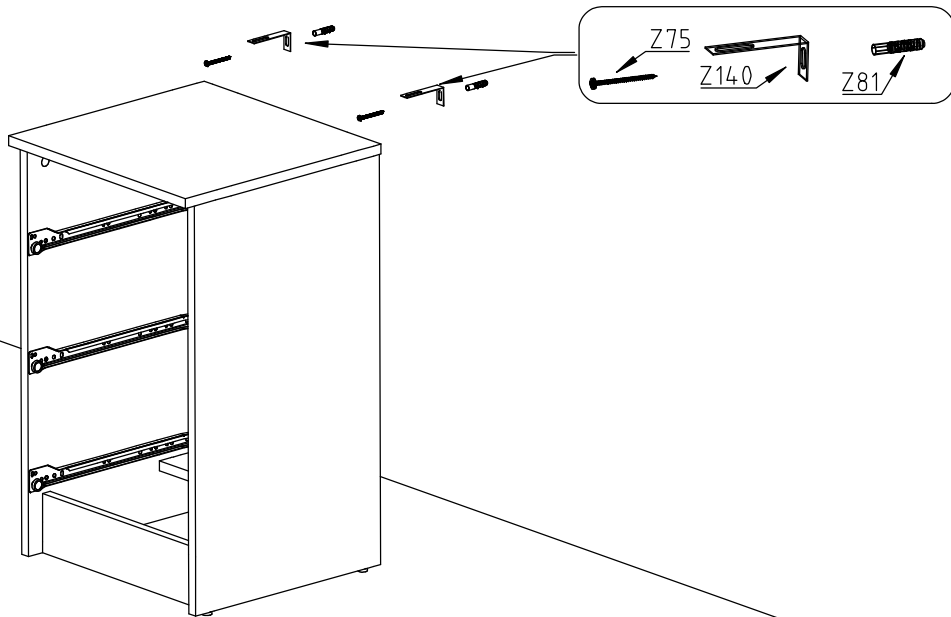

20.

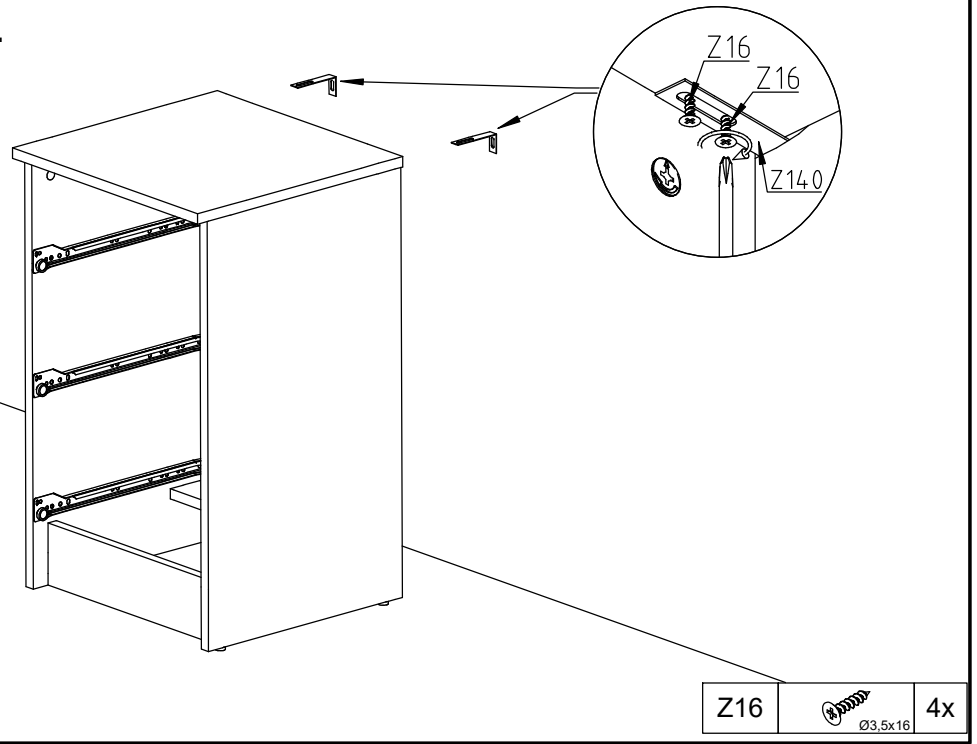

Z75		2x	Z140		2x
	Ø4.5x50				
			Z81		2x

21.



Z16		4x
	Ø3.5x16	