

MILO 3-in-1

Montage Anleitung / Notice de Montage / Assembling Instruction

ART. NR: 51 020 450

EAN NO.: 40 10 340 51 24 59

ORDER

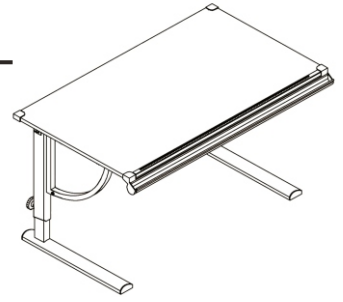

DE Wichtige Montage – Tipps hier zum herunterladen:

SE Viktiga monteringsstips att ladda ner här:

EN Important assembly tips to download here:

NO Viktige monteringsstips å laste ned her:

FR Conseils de montage importants - à télécharger ici :

FI Tärkeitä asennusvinkkejä ladattavaksi täältä:

IT Suggestimenti importanti per il montaggio da scaricare qui:

HU Fontos szerelési tippek itt tölthetők le:

CZ Důležité montážní tipy ke stažení zde:

EE Siit allalaadimiseks vajalikud olulised näpunäited

PT Dicas importantes de montagem para baixar aqui:

SL Pomembne nasvete za montažo, ki jih lahko prenesete tukaj:

ES Consejos de montaje importantes para descargar aquí:

RS Важне савете за монтажу преузмите овде:

PL Ważne wskazówki montażowe do pobrania tutaj:

RU Важные советы по сборке, которые можно скачать здесь:

NL Belangrijke montage tips om hier te downloaden:

TR Buradan indirmek için önemli montaj ipuçları:

SK Dôležité montážne tipy na stiahnutie tu:

GR Σημαντικές συμβουλές συναρμολόγησης για λήψη εδώ:

BG Важни съвети за сглобяване, които да изтеглите от тук:

LT Svarbūs surinkimo patarimai, kuriuos galite atsisiųsti čia:

RO Sfaturi importante de asamblare pentru descărcare aici:

LV Svarīgi montāžas padomi, ko lejupielādēt šeit:

HR Ovdje možete preuzeti važne savjete za montažu:

LU Wichtig Assemblée Tipps fir hei erofzelueden:

DK Vigtige monteringsstips til download her:

ARB :صائح مهمة حول التجميع للتنزيل من هنا



MILO 3-in-1

Montage Anleitung / Notice de Montage / Assembling Instruction

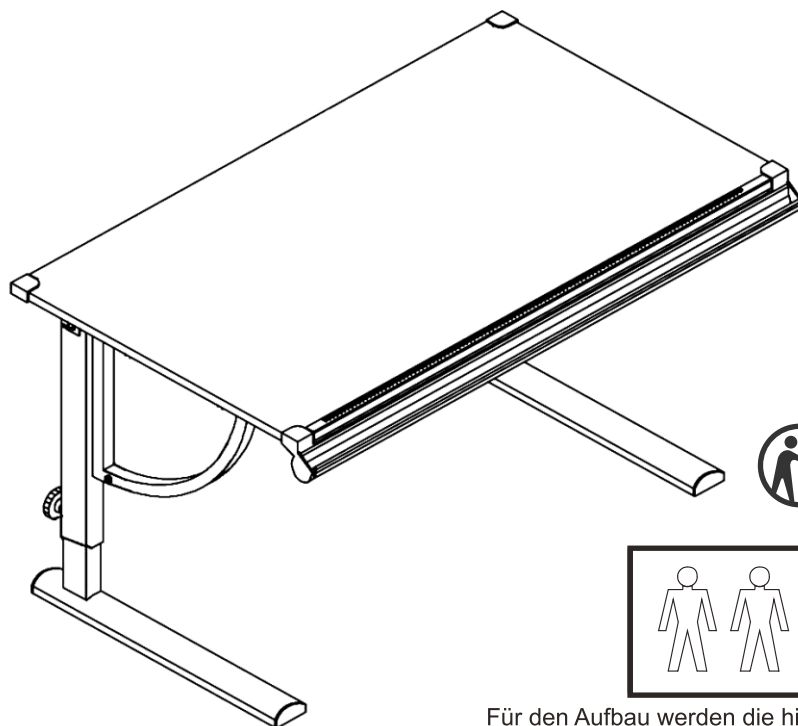

LE TRI
+ FACILE





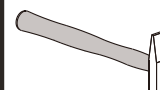
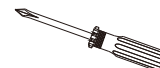



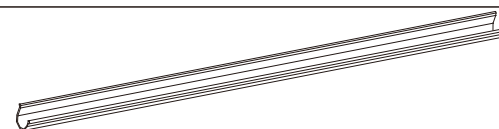
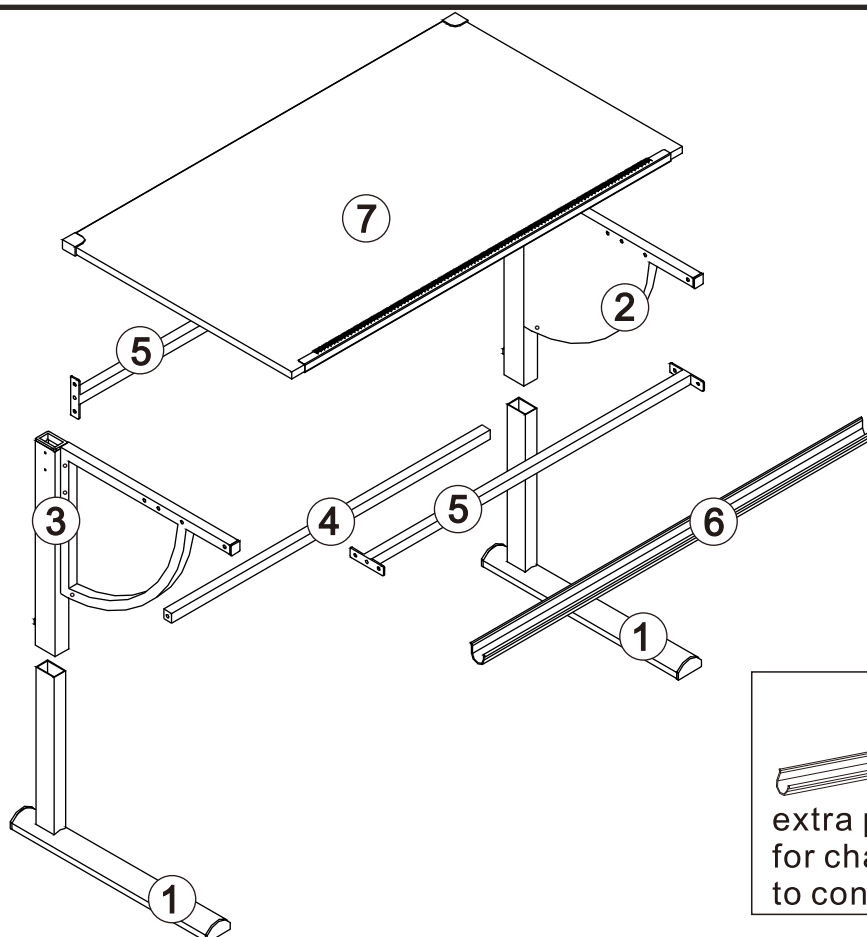



BAC
DE
TRI













Für den Aufbau werden die hier abgebildeten Werkzeuge benötigt.
Avant le montage, se munir des outils nécessaires.
For the assembly you need the tools shown above.

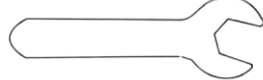

extra pencil holders x 2 pcs are
for changing at anytime subject
to consumer's preference

A		M6x45	2pcs
B		M6x38	8pcs
C		M6x15	6pcs
D		M6x12	2pcs
E		M5x12	2pcs
F		M4x15 Long	16pcs
G		Metal 13x1.5	18pcs
H		Metal 16x1.0	4pcs
I		PVC 15x2.0	4pcs
J		M6x10	6pcs

K		M6x10	4pcs
L		M16x53	2pcs
M			1pc
N			1pc
O			1pc
P			2pcs
Q			2pcs
R			2pcs
S			1pc
T			1pc

01

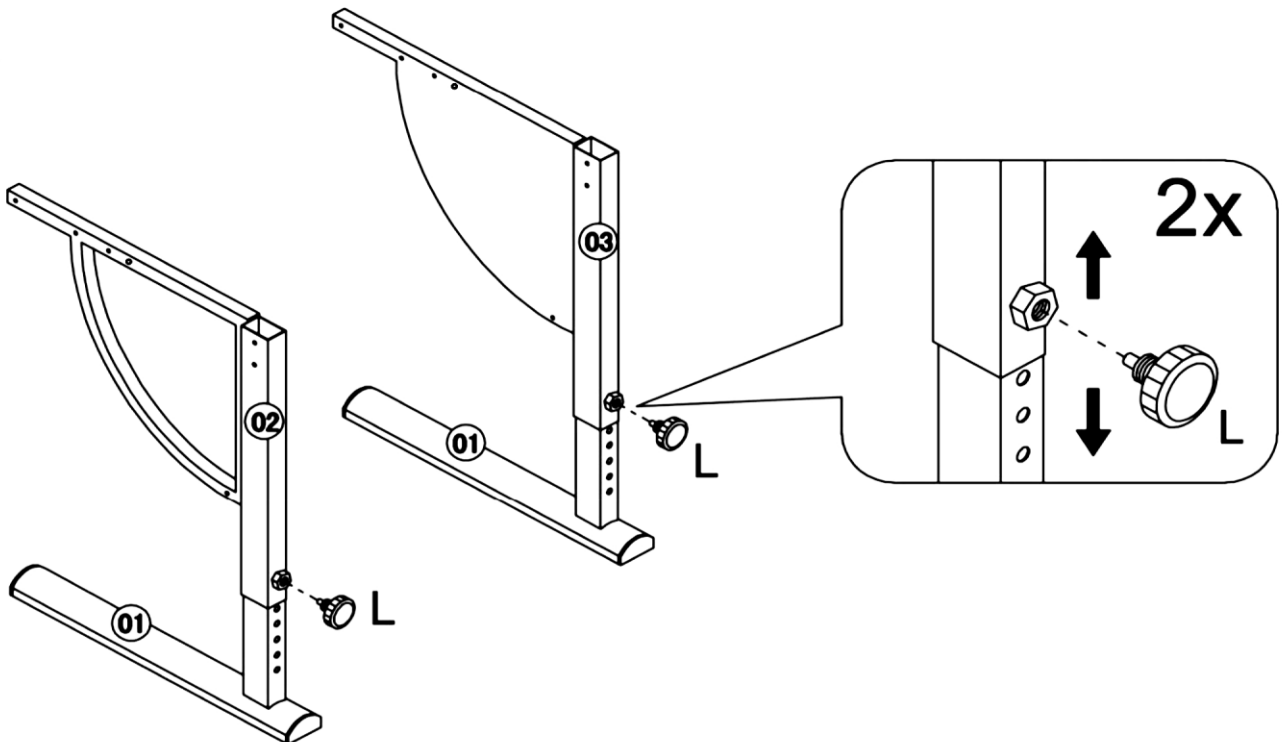

02

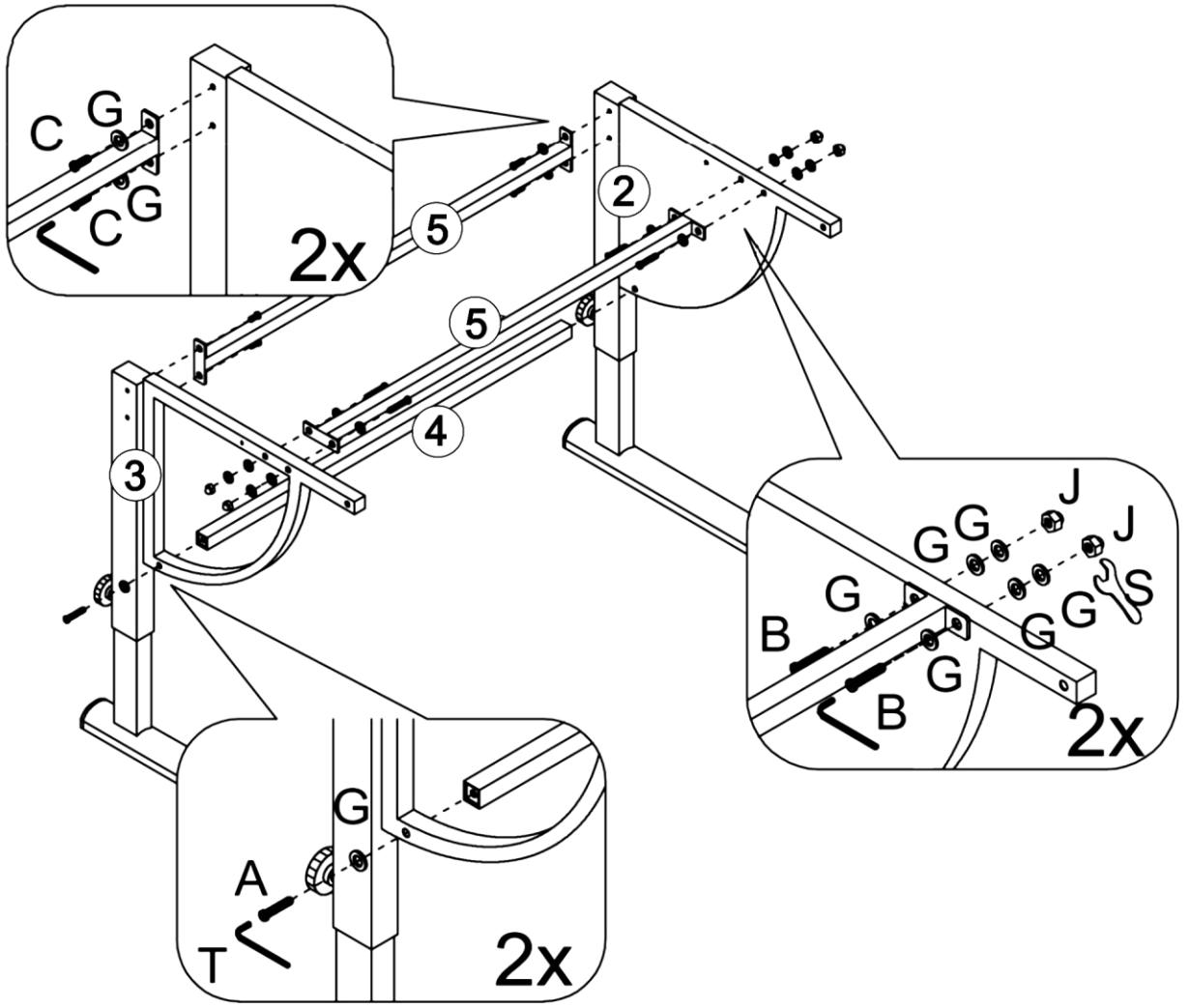

03

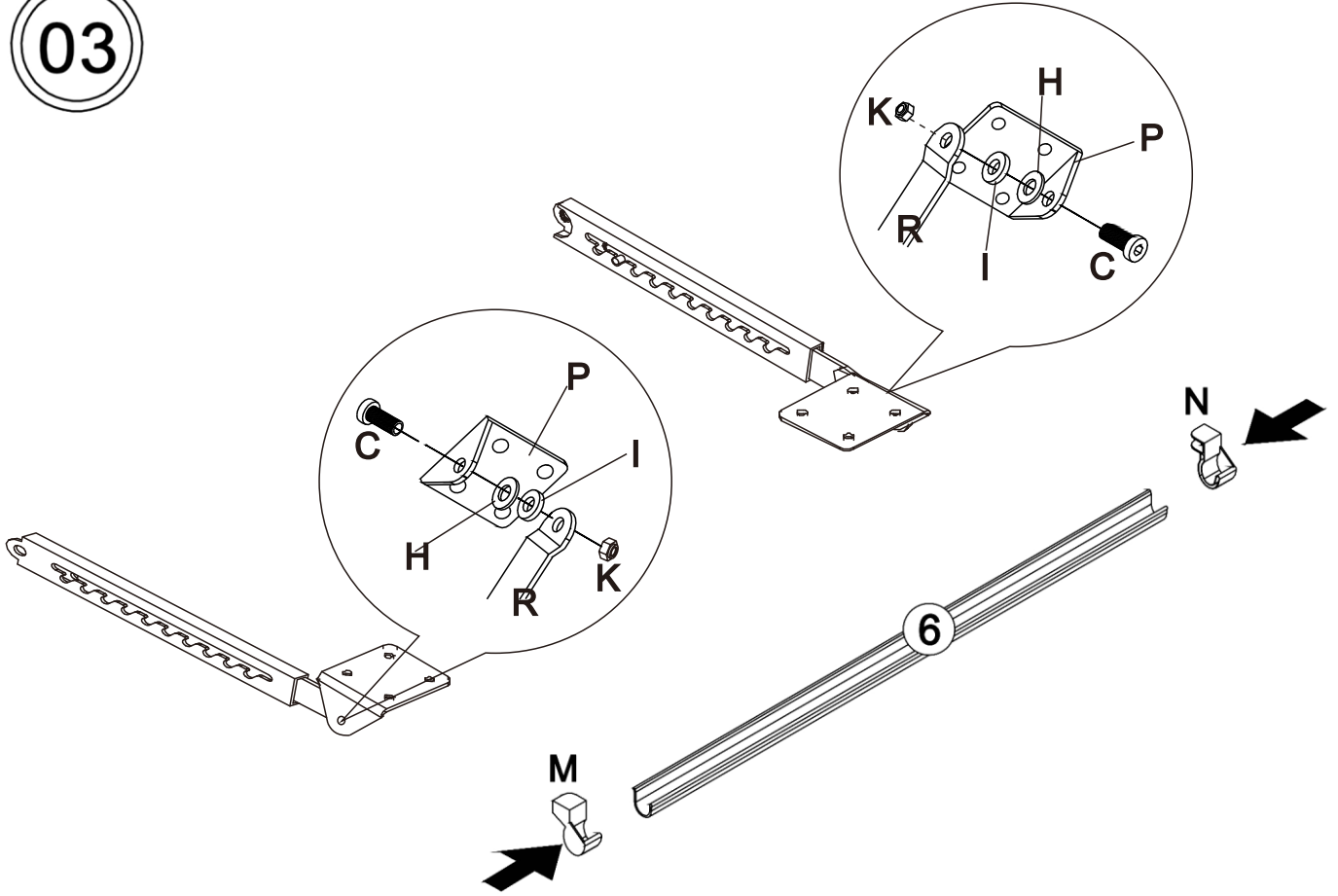

04

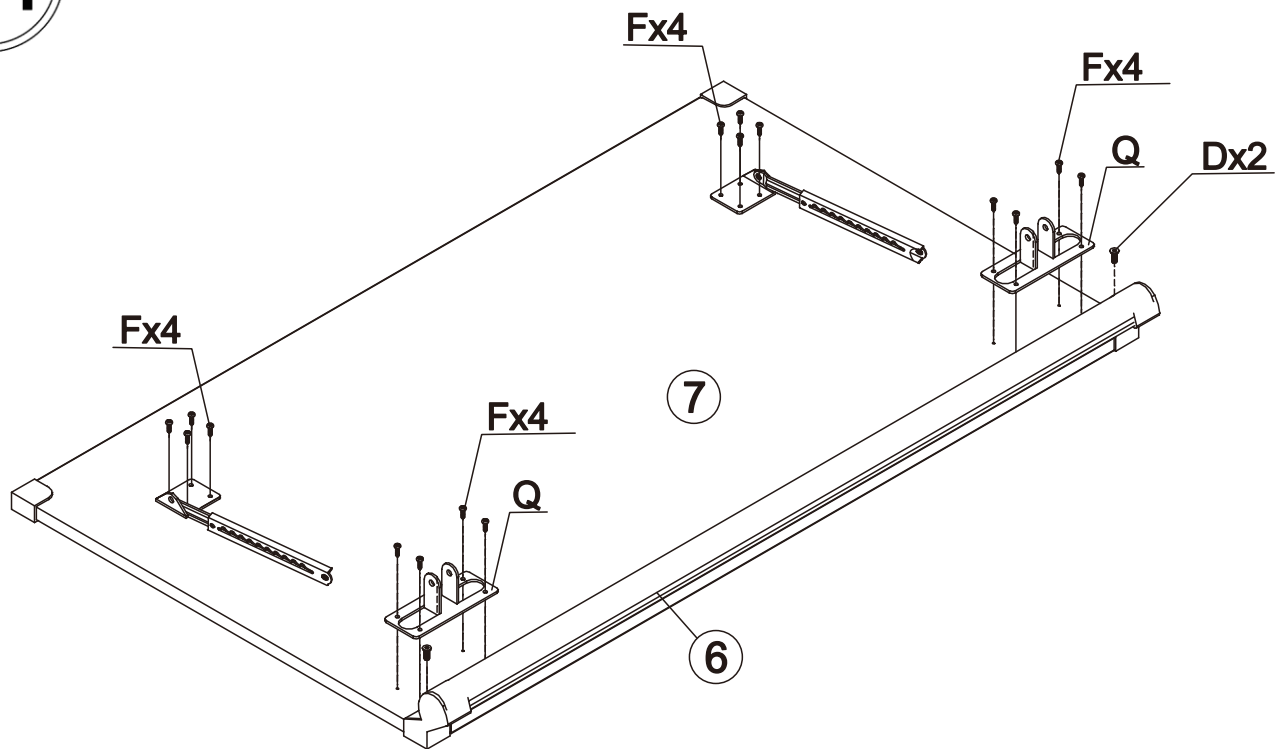

05

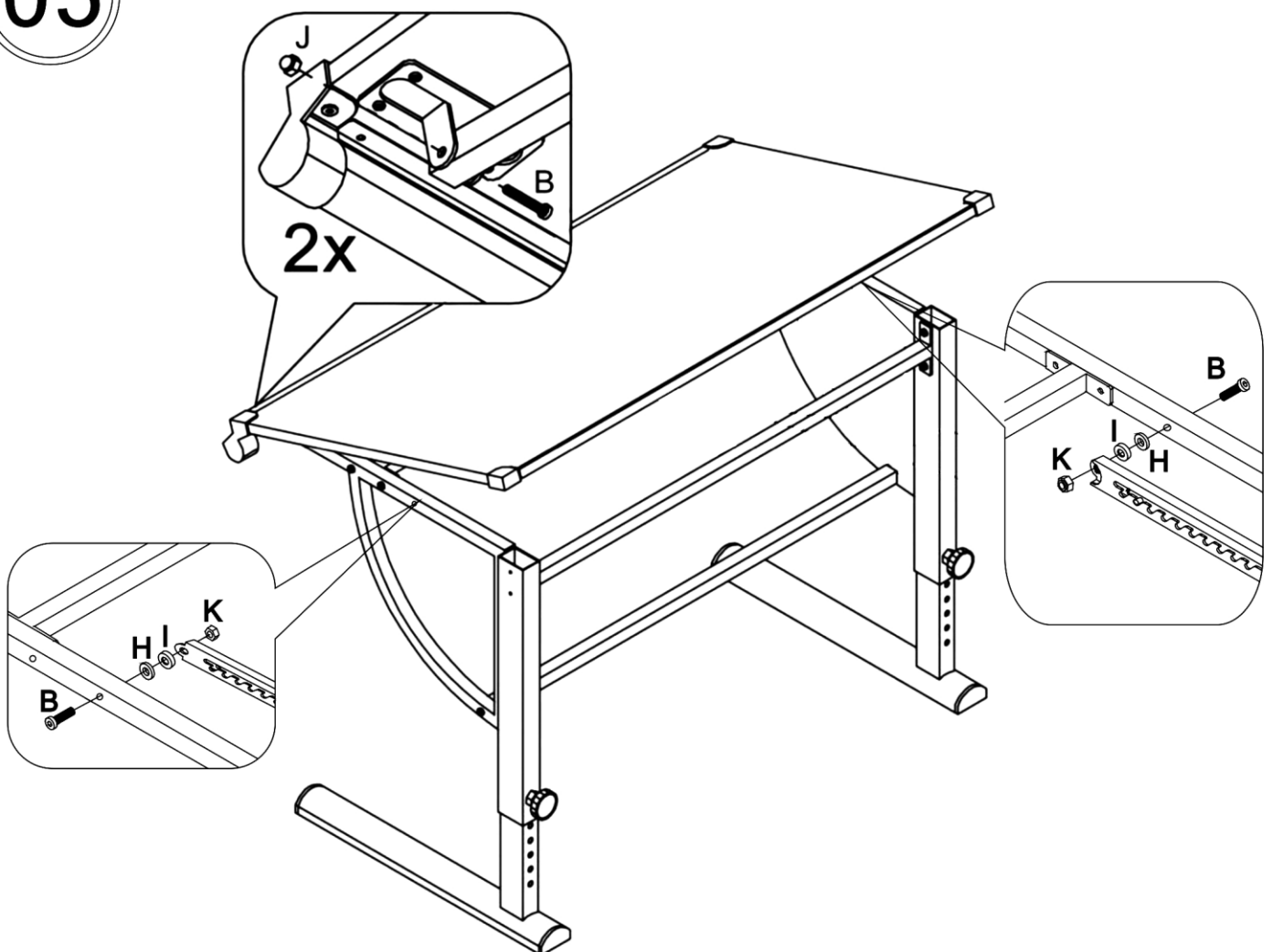

06

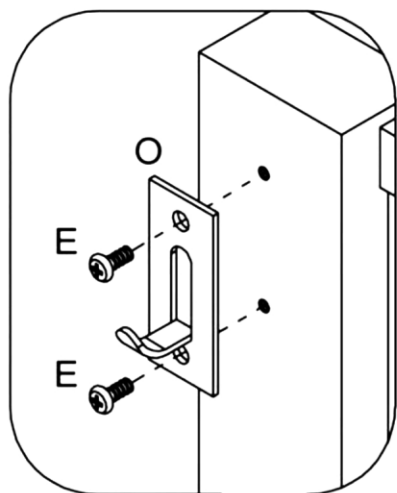

Anmerkung

Zur Höhenverstellung des Tisches:

1. Lösen Sie den Feststellknopf und ziehen Sie ihn heraus.
2. Stellen Sie die gewünschte Höhe ein.
3. Lassen Sie den Feststellknopf in der gewünschten Position einrasten und drehen Sie ihn fest.

Notice

To adjust the height:

1. Unscrew the knob and pull it.
2. Adjust the desired height.
3. Tighten the knob.

Remarque

Pour régler le plateau en hauteur:

1. Dévissez légèrement le bouton et tirez-le vers vous.
2. Réglez le plateau à la hauteur désirée.
3. Relâchez le bouton et revissez-le.

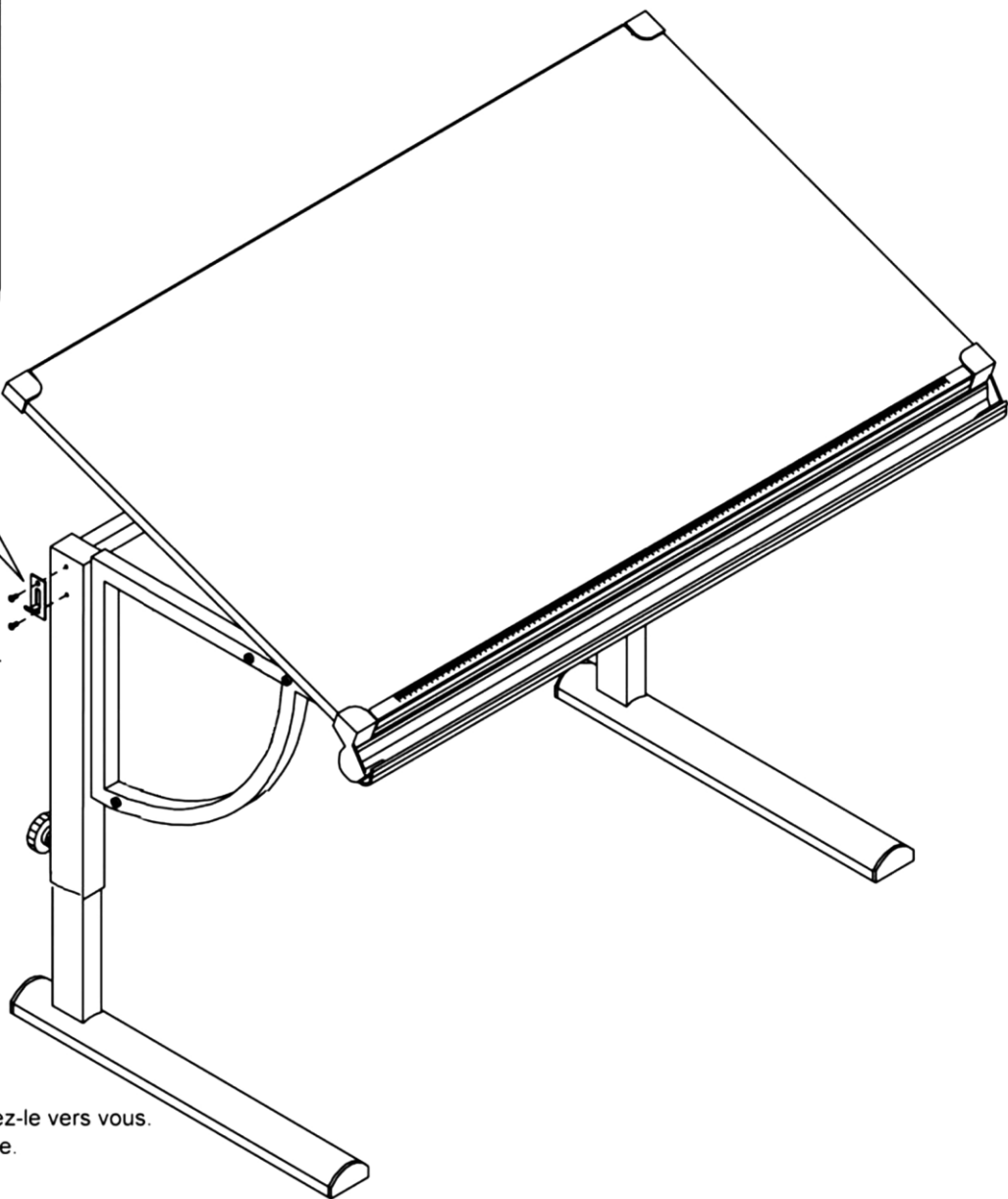

Achtung



Warning



Attention

Möbel nie im befüllten Zustand verschieben. Sie können instabil werden, zusammenbrechen, umkippen oder andere Schäden können entstehen. Auch die Befüllung kann beschädigt werden.

Do not move your piece of furniture if loaded. Doing so, your piece of furniture could become instable, collapse, tip over, and/or cause serious injuries.

Ne pas déplacer l'unité lorsqu'elle est chargée. Faire ainsi peut causer l'instabilité, l'effondrement ou le renversement du meuble et/ou des endommagements sérieux.