

LIORA 090

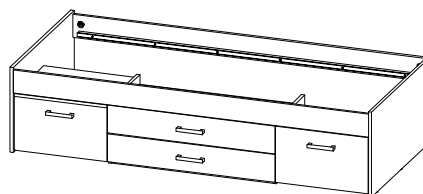

Montageanleitung / Notice de montage / Assembling Instruction

ART. NR: 55034090

EAN: 4010340530903

ORDER: 19153

DE: Wichtige Montage - Tipps hier zum herunterladen:

LU: Wichtig Versammlungsvirschléi eroflueden:

EN: Important assembling suggestions download:

LV: Svarīgu montāžas ieteikumu lejupielāde:

FR: Conseils de montage importants à télécharger ici:

NL: Belangrijke montagesuggesties downloaden:

BG: Важни съвети за сглобяване, които да изтеглите от тук:

NO: Viktige nedlastingsforslag:

CZ: Důležité montážní tipy ke stažení zde:

PL: Pobieranie ważnych sugestii montażowych:

EE: Olulised kokkupanemisetepanekute allalaadimine:

PT: Download de sugestões importantes de montagem:

DK: Vigtige montage tips til at downloade:

RO: Descărcare de sugestii importante de asamblare:

ES: Descarga de sugerencias de montaje importantes:

RS: Преузимање важних предлога за састављање:

FI: Tärkeät kokoamisedotukset ladataan:

RU: Важные предложения по сборке скачать:

GR: Λήψη σημαντικών προτάσεων συναρμολόγησης:

SL: Prenos pomembnih predlogov za sestavljanje:

HR: Preuzimanje važnih prijedloga za sastavljanje:

SE: Viktiga hämtningsförslag:

HU: Fontos összeszerelési javaslatok letöltése:

SK: Stiahnutie dôležitých návrhov na zostavenie:

IT: Download importanti suggerimenti di montaggio:

TR: Önemli montaj önerileri indir:

LT: Svarbūs surinkimo pasiūlymai atsisiųsti:

ARB: قةمعملأ عيمجتلأ تاحارتقال يزنن:

 **Inter Link**

Z.A du Niederwald
F-67470 Seltz
www.interlink-sas.com



LIORA 090

OPTION L

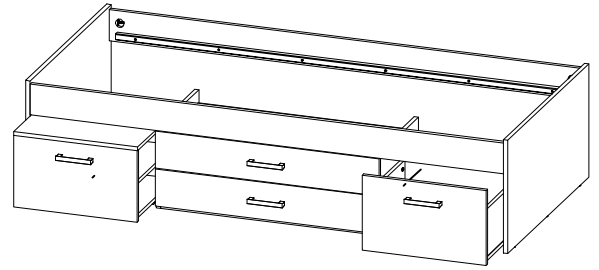

OPTION R

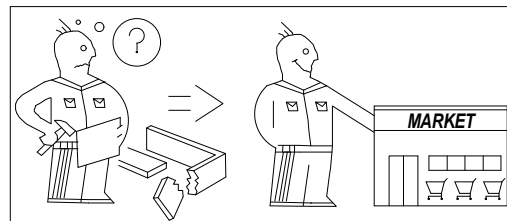
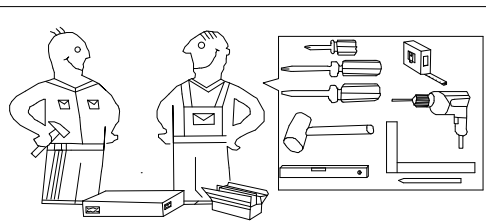
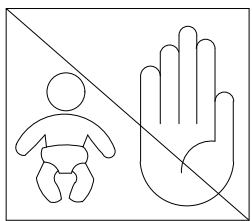
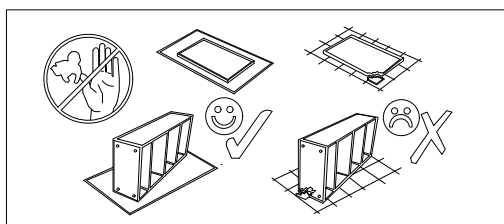
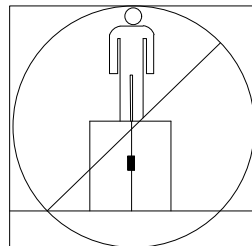
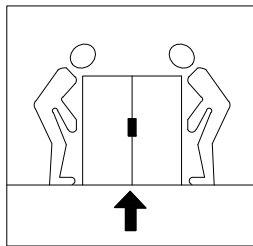
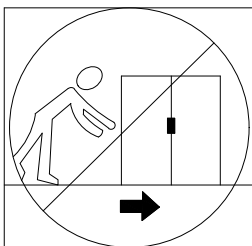
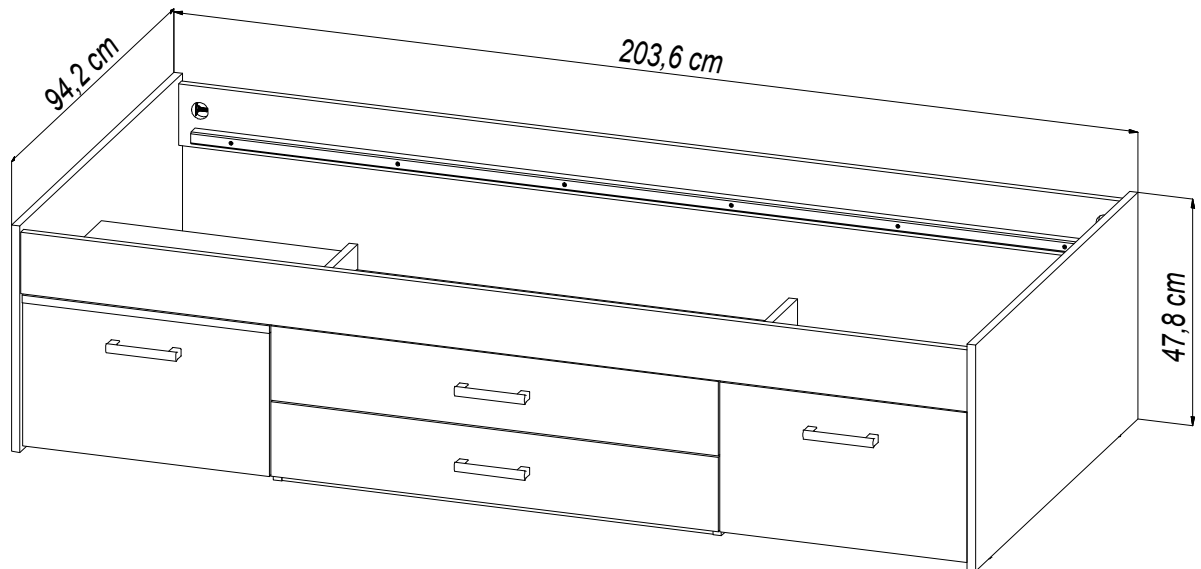
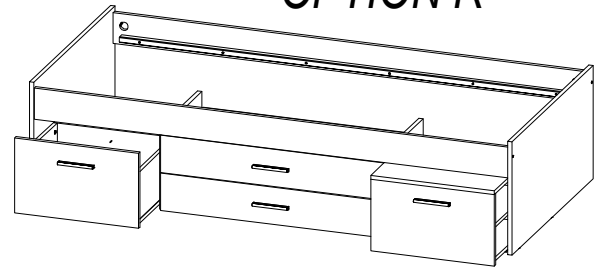

LIORA 090

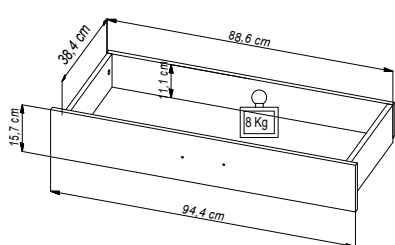
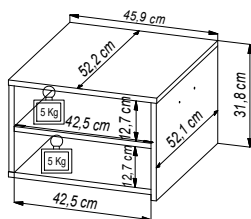
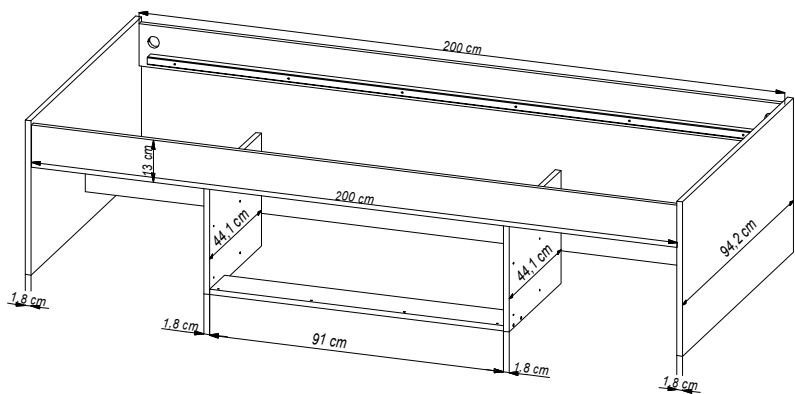
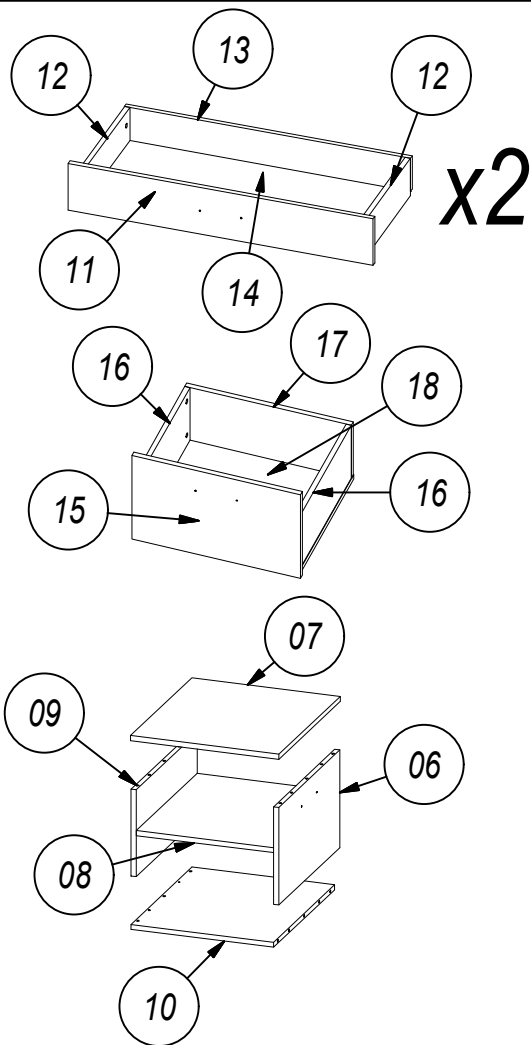
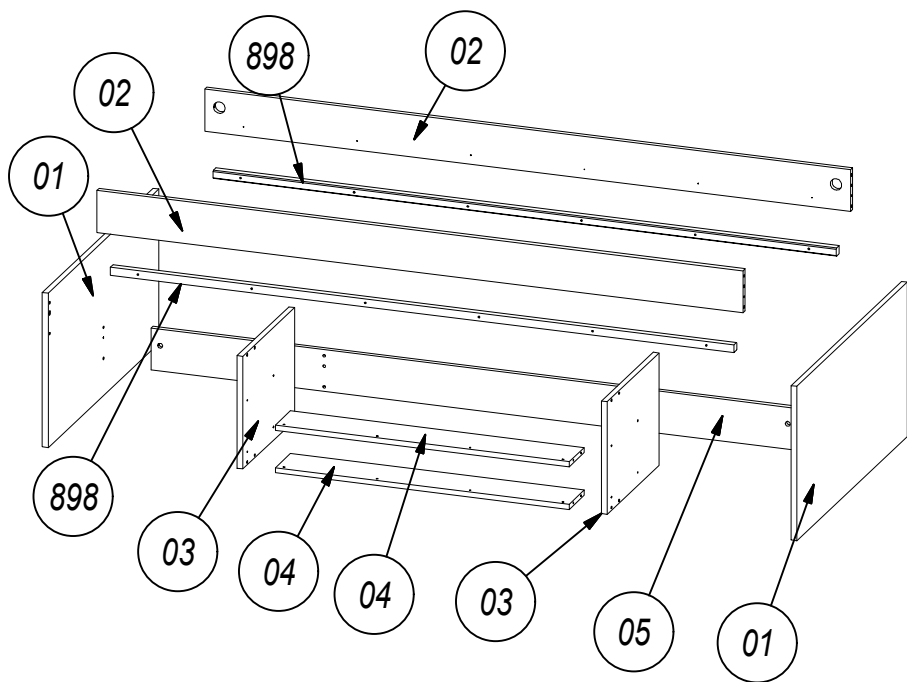



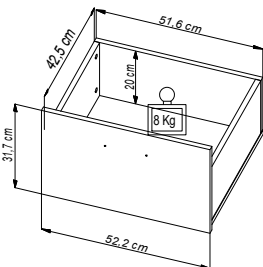





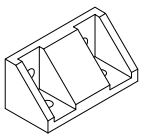
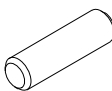
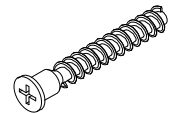

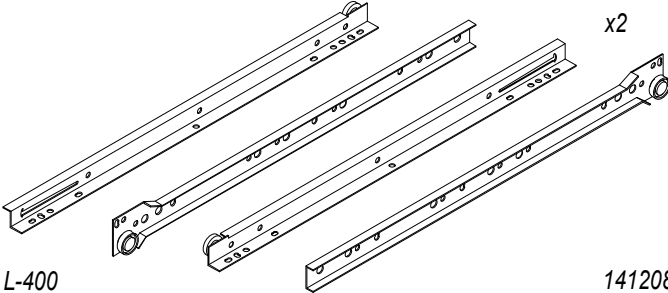

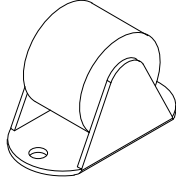

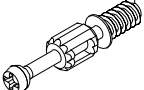

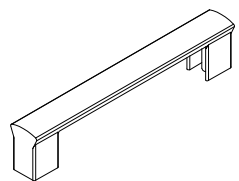
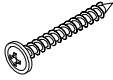
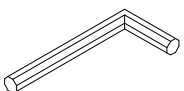
x2

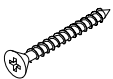
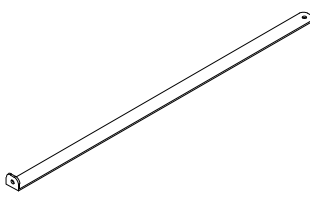

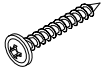

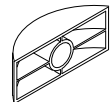
AI No.	Qty	H	W	D	PKG
01	2	942	478	18	1/2
02	2	2000	130	18	2/2
03	2	441	349	18	2/2
04	2	910	128	16	1/2
05	1	2000	130	16	2/2
06	1	521	302	16	2/2
07	1	522	459	16	2/2
08	1	518	425	16	2/2
09	1	519	269	16	2/2
10	1	520	442	16	2/2
11	2	944	157	16	1/2
12	4	384	125	16	1/2
13	2	886	111	16	1/2
14	2	865	406	2,5	1/2
15	1	522	317	16	2/2
16	2	425	200	16	2/2
17	1	516	200	16	1/2
18	1	519	442	16	1/2
898	2	1930	25	25	2/2

LIORA 090

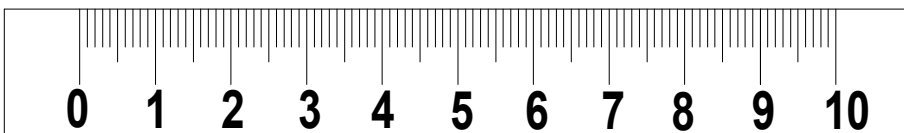
 x2 56590	 x56 Ø8x28 1018	 x14 Ø7x50 1354	 x26 Ø15x12,5 123894
 L-400 141208		 x4 1302	 x8 2407
		 x10 1305	
 L-11 mm x26 11809	 x20 UP Ø4x13 1064	 x8 EURO S Ø6x9,5 1007	 x4 153498
 x4 UP Ø4x35 1059	 x1 L-6 107947	 x8 UP Ø3x20 1056	
 x16 US Ø3,5x13 1011	 x12 US Ø4x35 1067	 x2 151500	 x4 Ø6x60 154806
 x8 UP Ø4x30 1012	 x26 Ø20 143031		 x4 Ø35 154809
 x4 M6x10x13 154808	 x4 M6 154807		



L-11 mm	11809
	x8
Ø8x28	1018
	x16
Ø15x12,5	123894
	x8

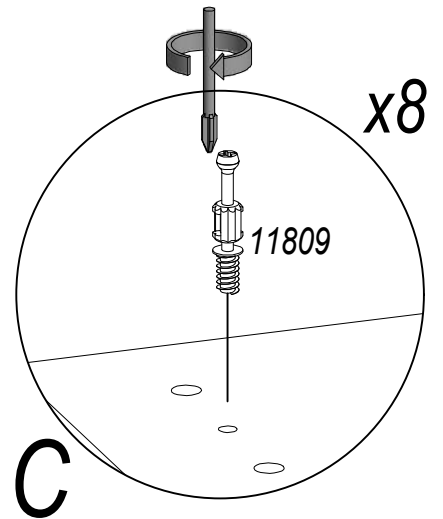
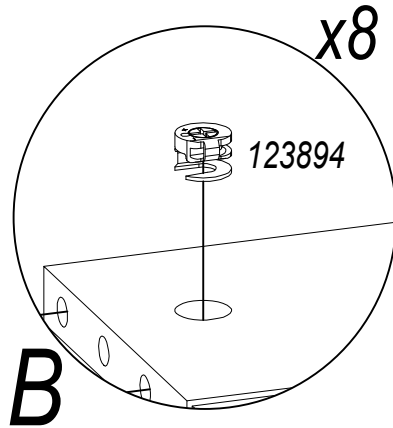
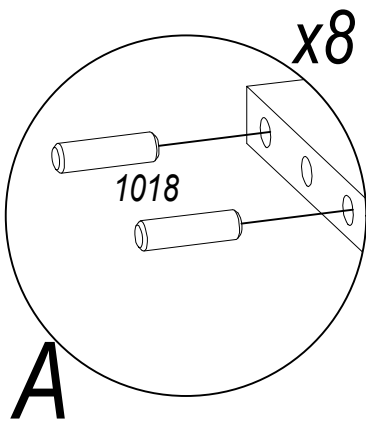
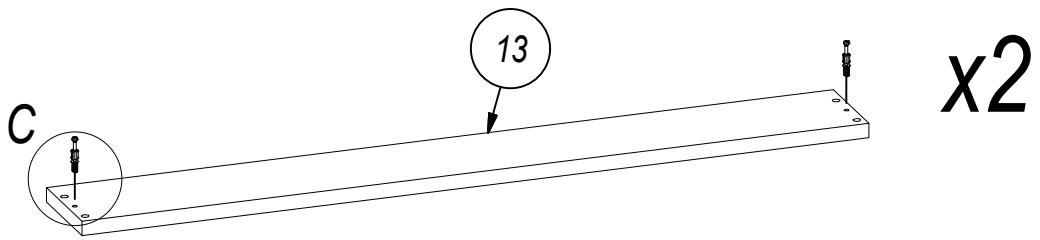
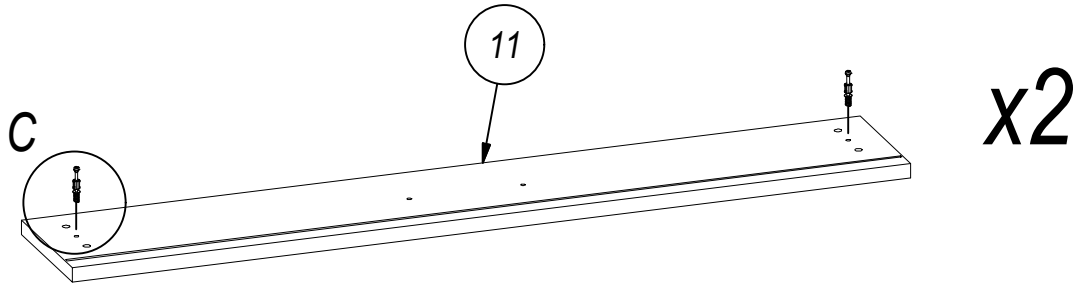
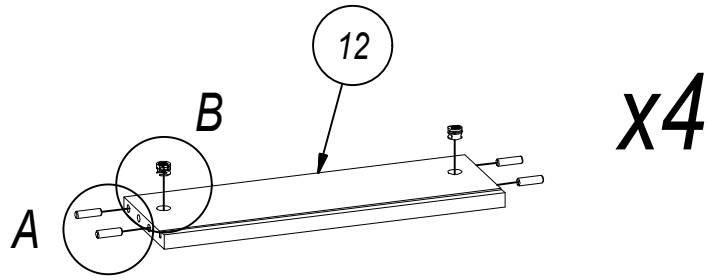

2

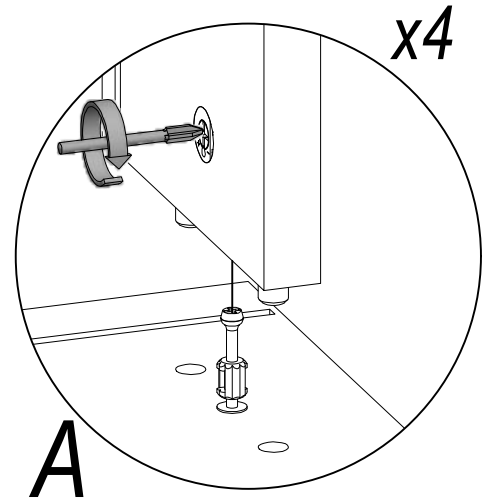
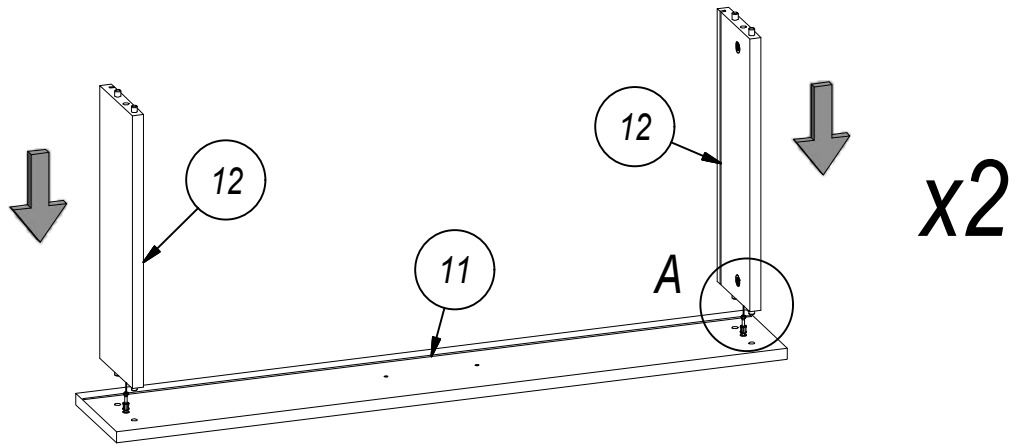

3

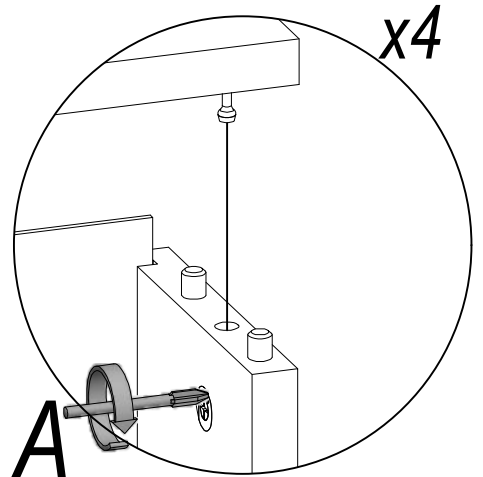
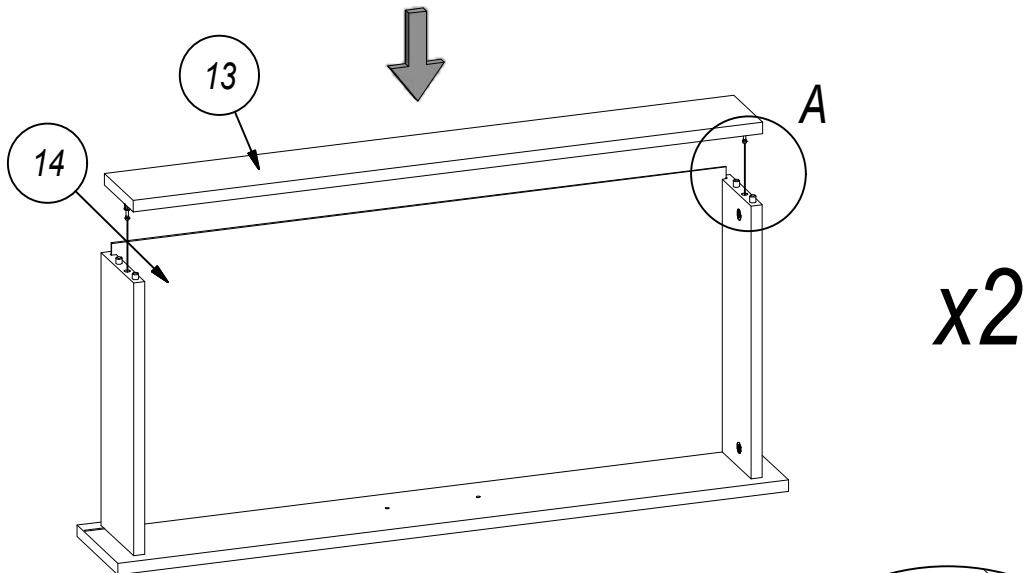

4

- UP Ø3x20 1056 x8
- 1302 x4
- 151500 x2
- UP Ø4x13 1064 x4

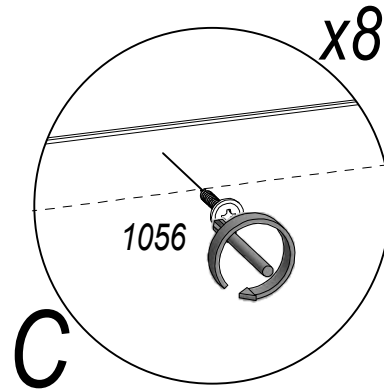
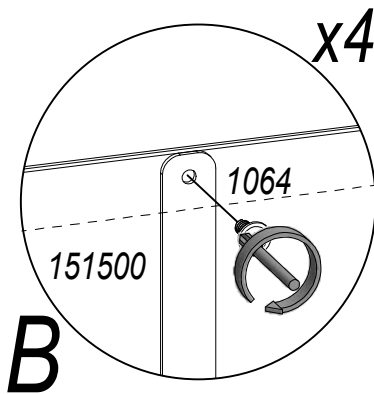
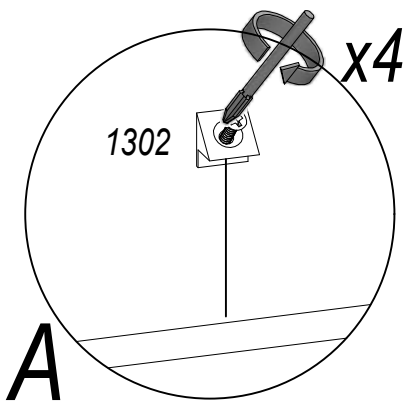
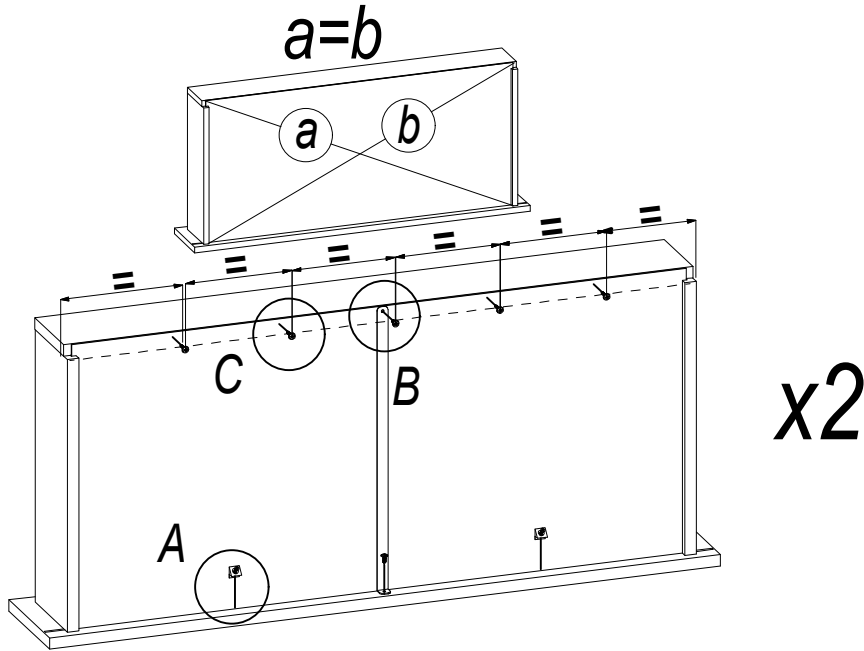



5

- L-400 141208 x2

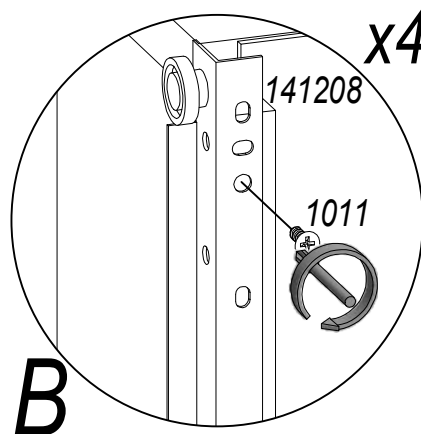
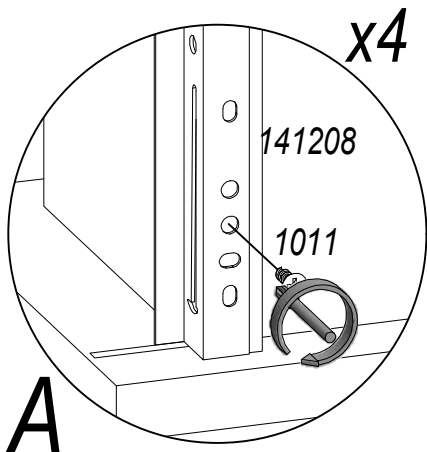
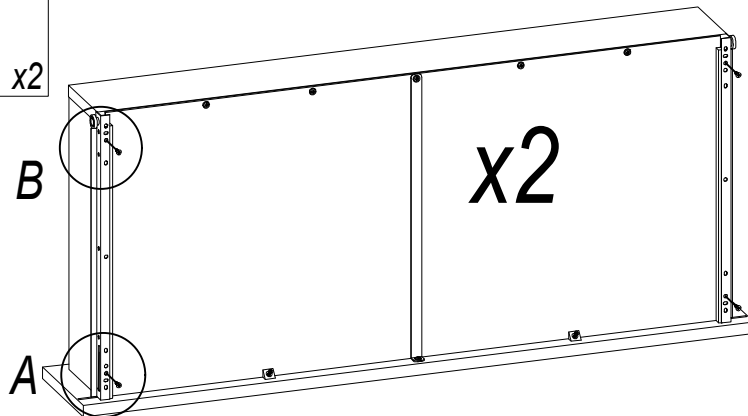
- US Ø3,5x13 1011 x8



L-11 mm	11809
	x8
Ø15x12,5	123894
	x8
Ø8x28	1018
	x8

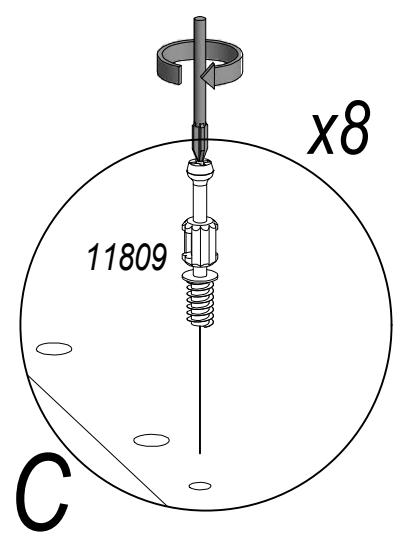
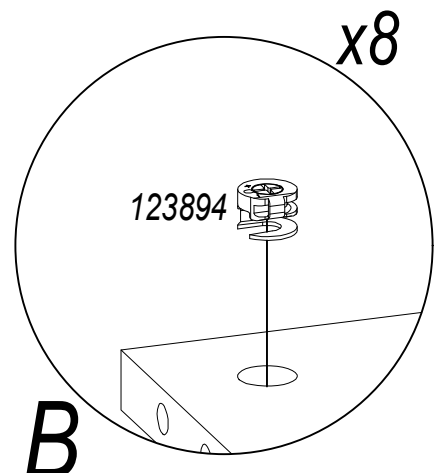
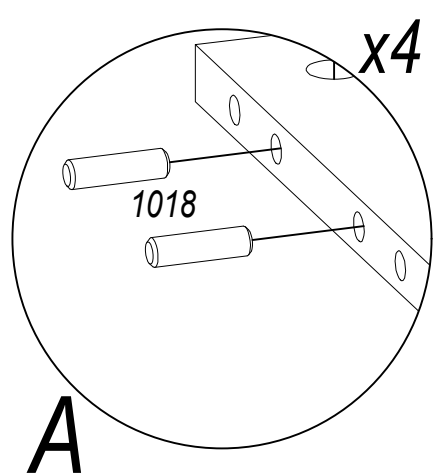
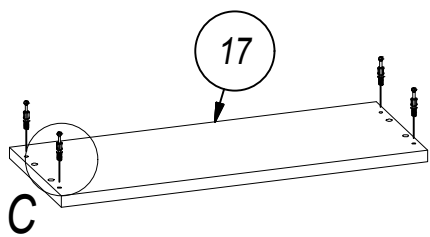
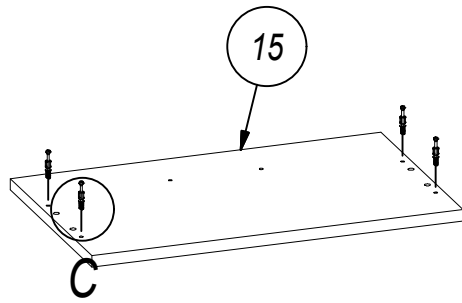
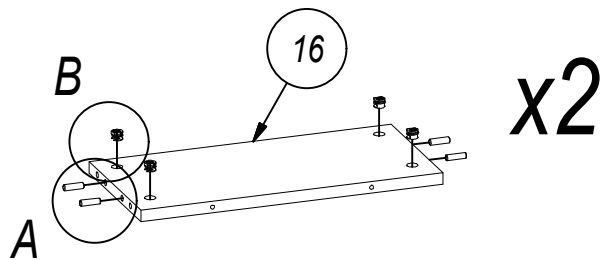

7

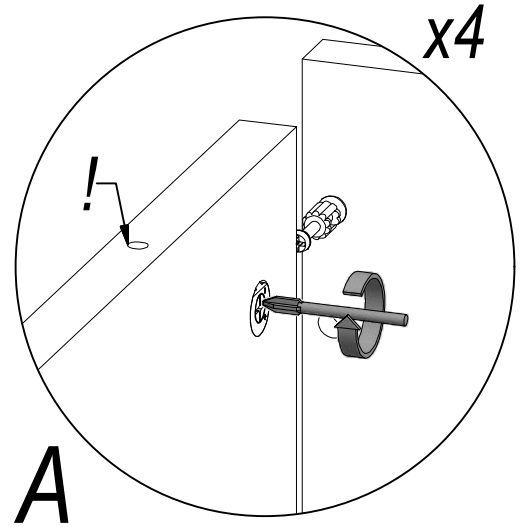
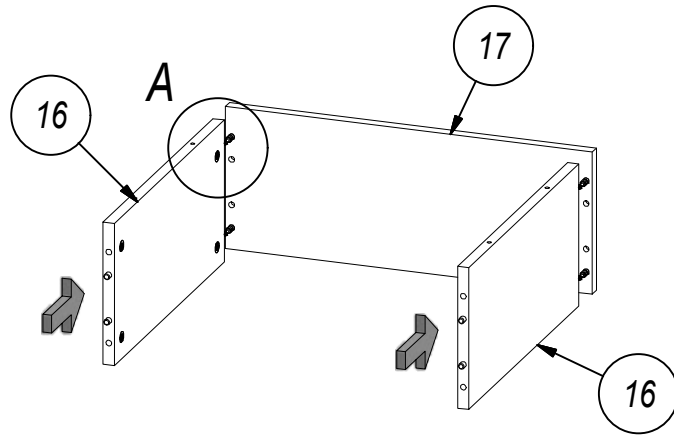

8

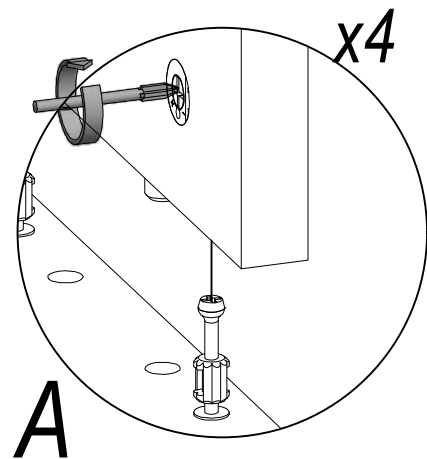
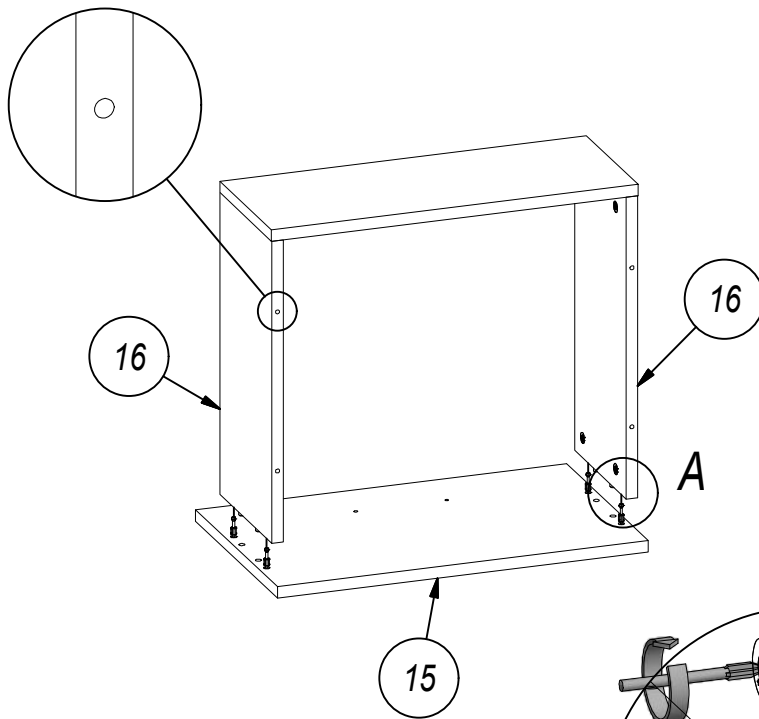

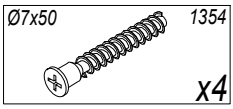

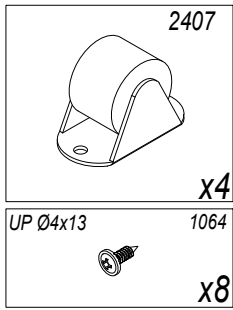
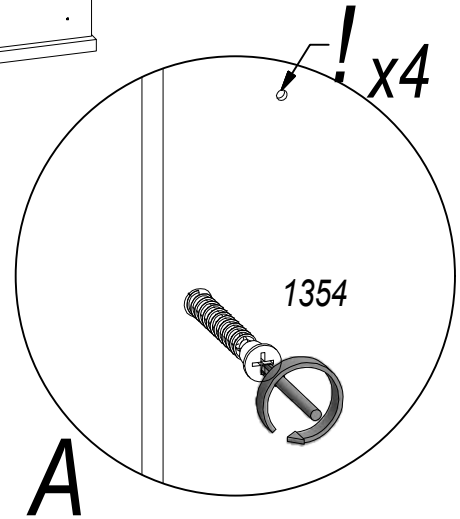
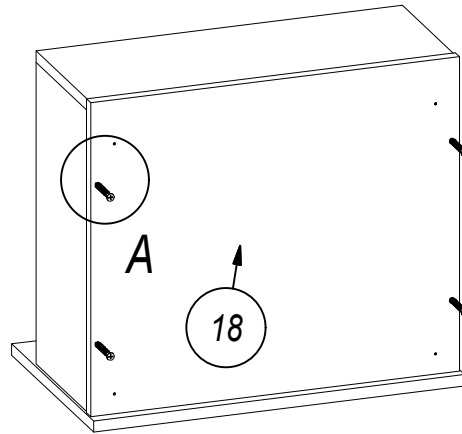

9

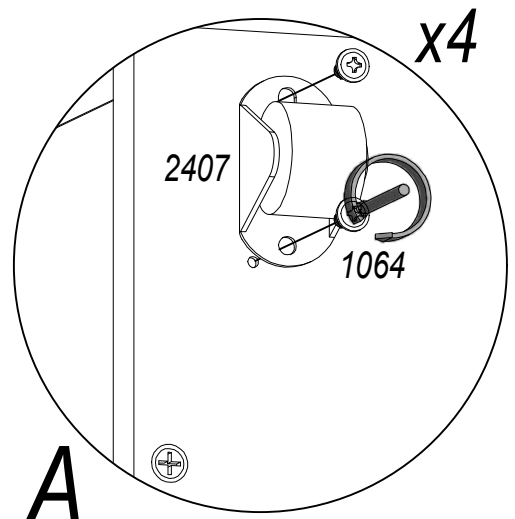
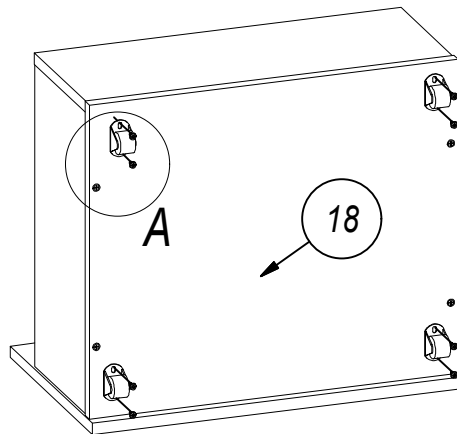

10

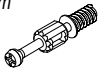

L-11 mm	11809
	x8
Ø15x12,5	123894
	x8
Ø8x28	1018
	x16

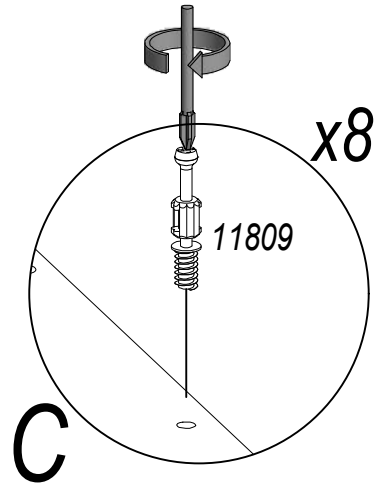
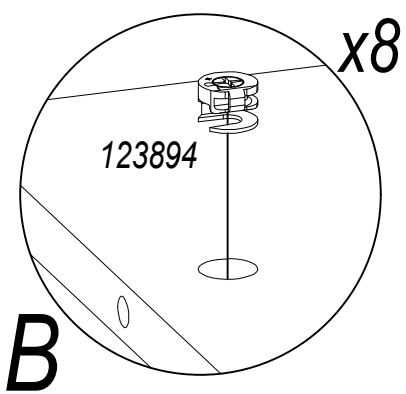
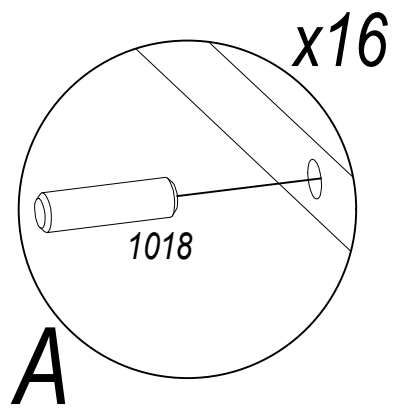
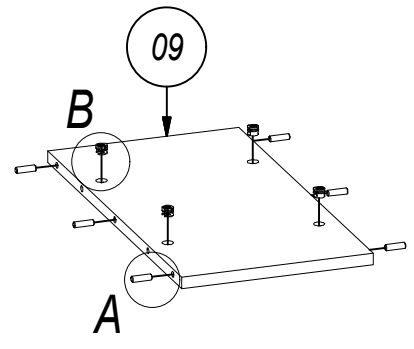
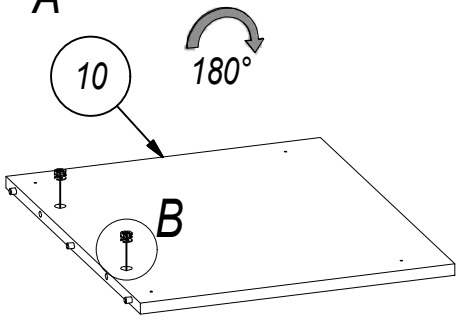
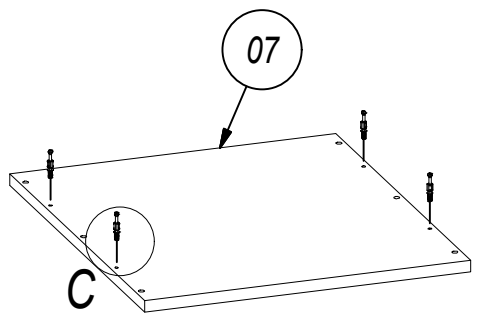
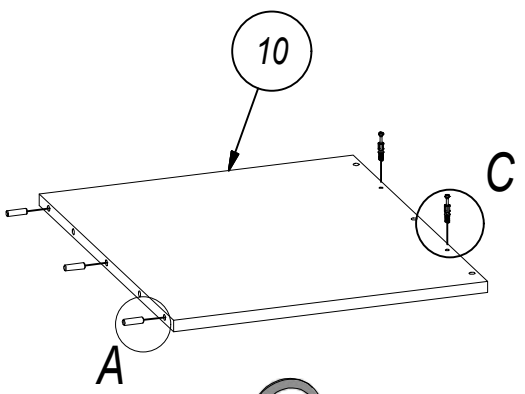
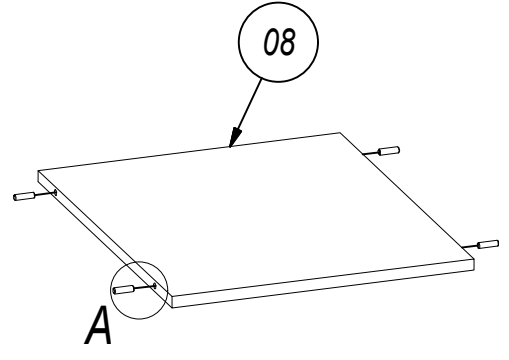
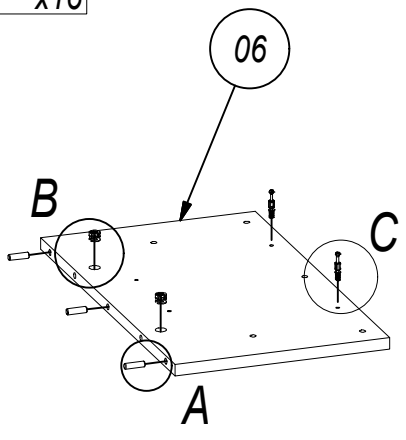

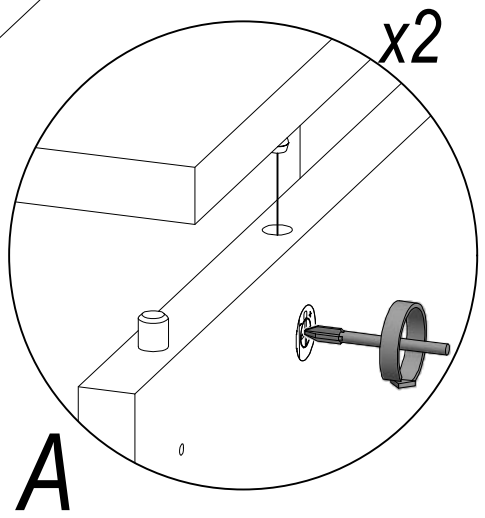
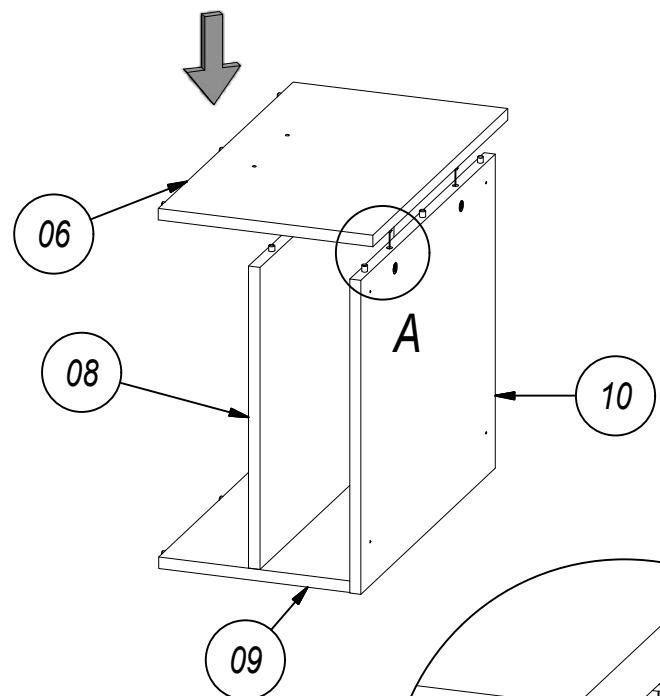
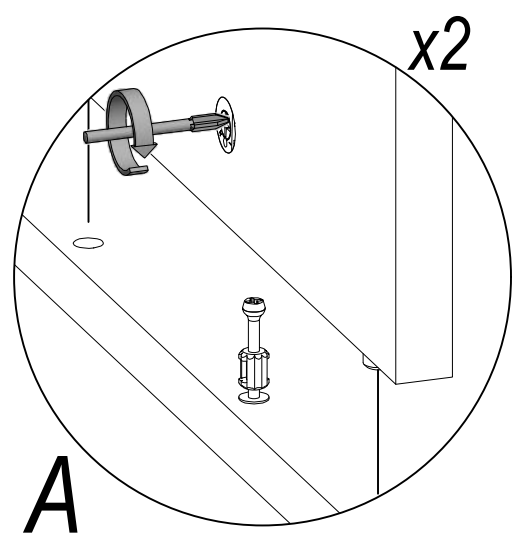
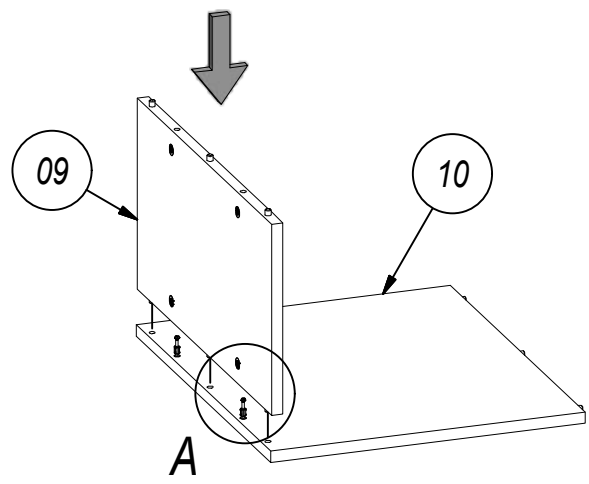

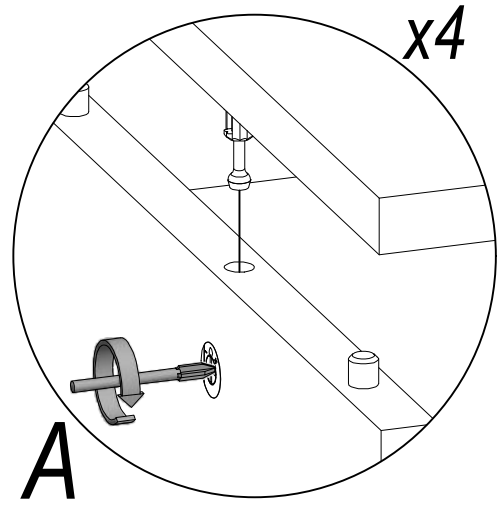
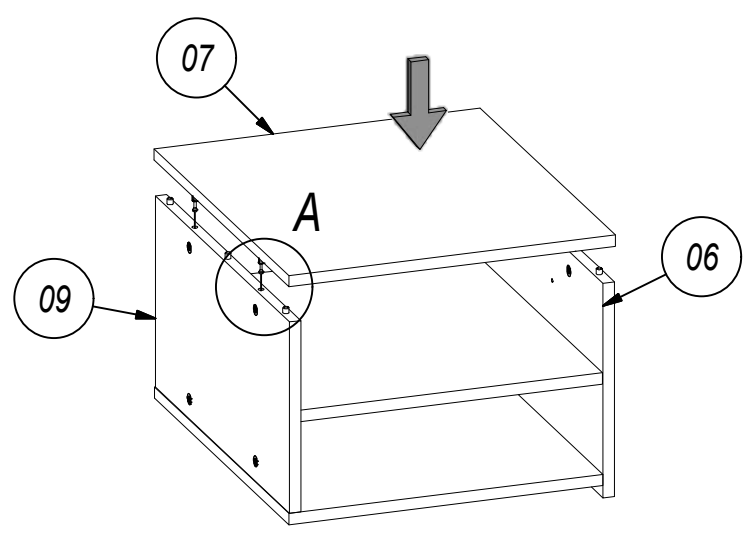

- 2407
- x4
- UP Ø4x13
- 1064
- x8

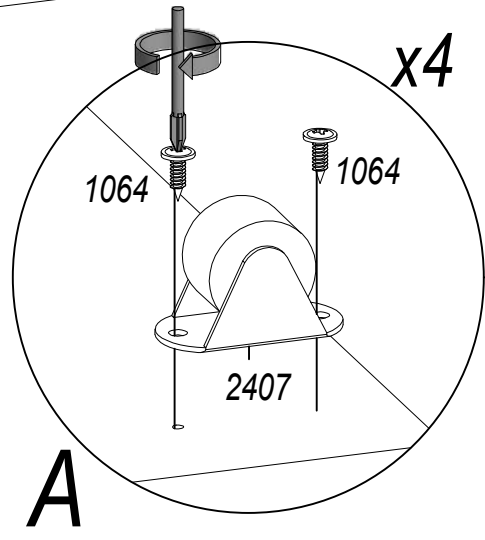
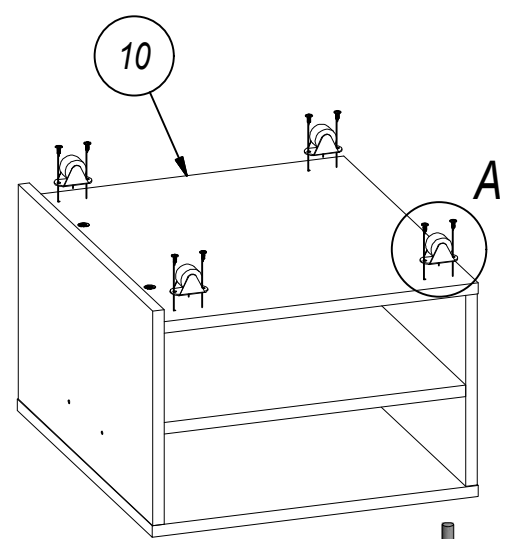

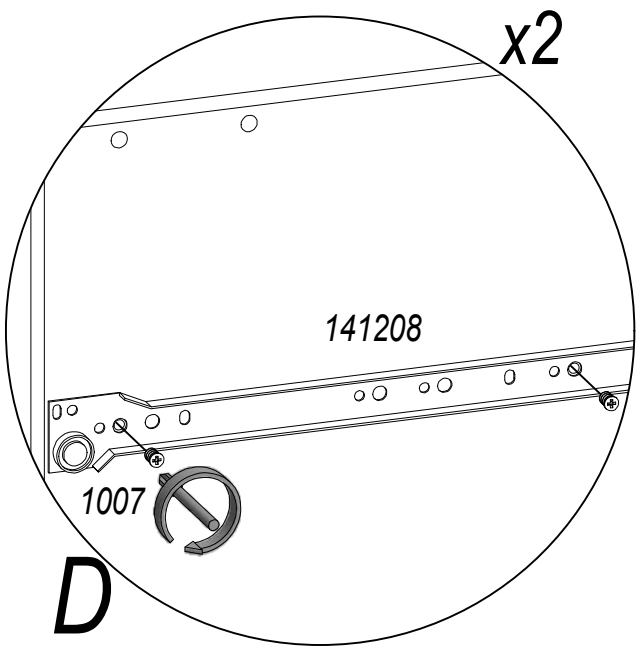
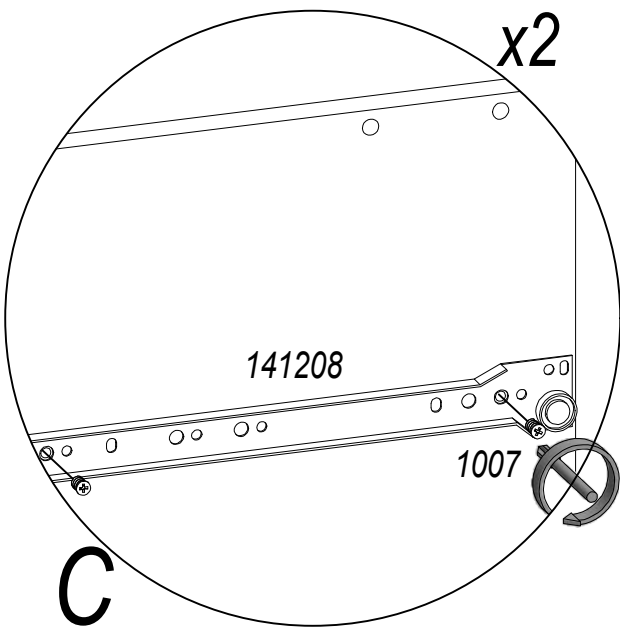
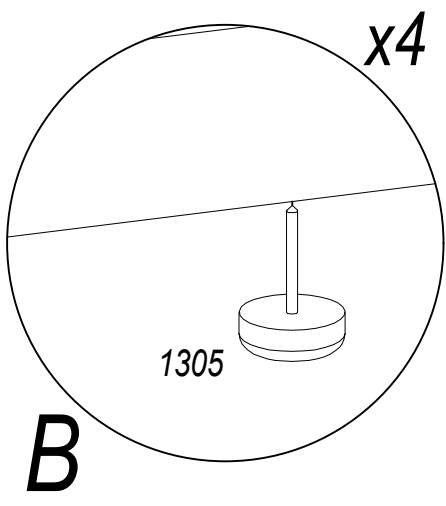
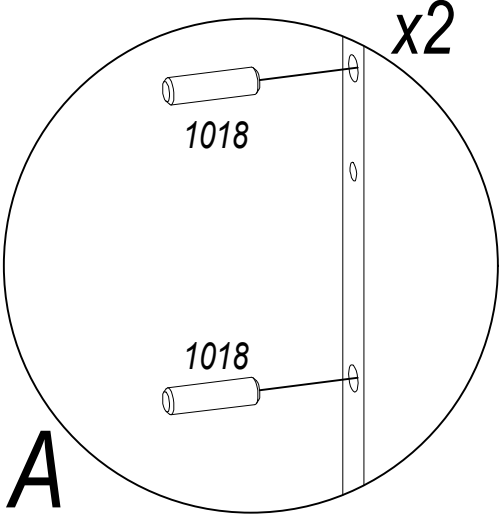
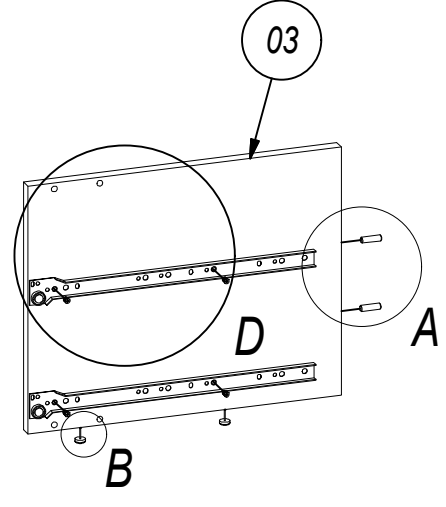
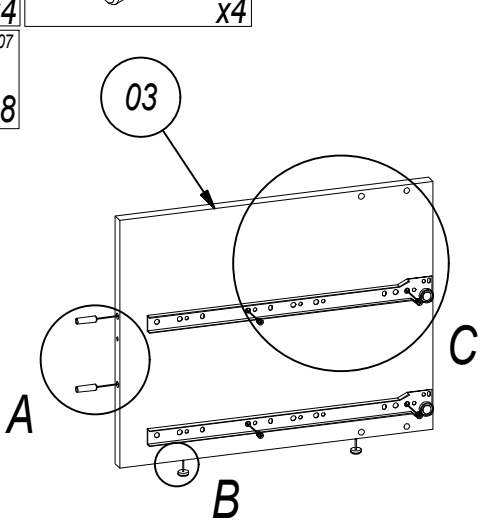
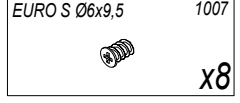
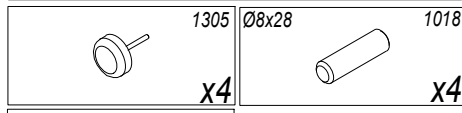
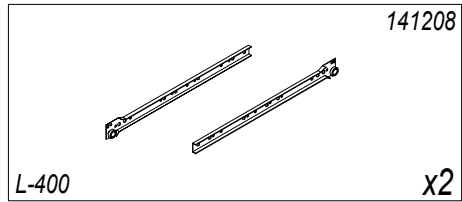

US Ø4x35 1067 x12	Ø8x28 1018 x12	Ø15x12,5 123894 x2
-------------------------	----------------------	--------------------------

17

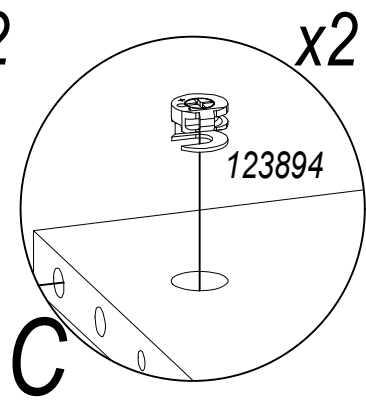
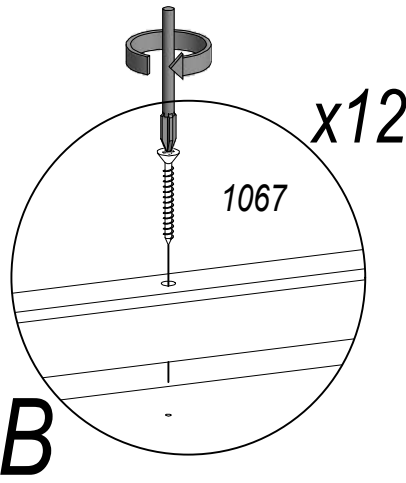
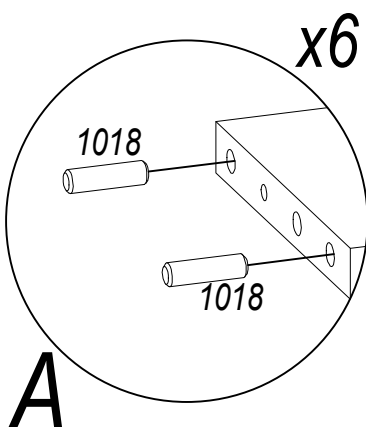
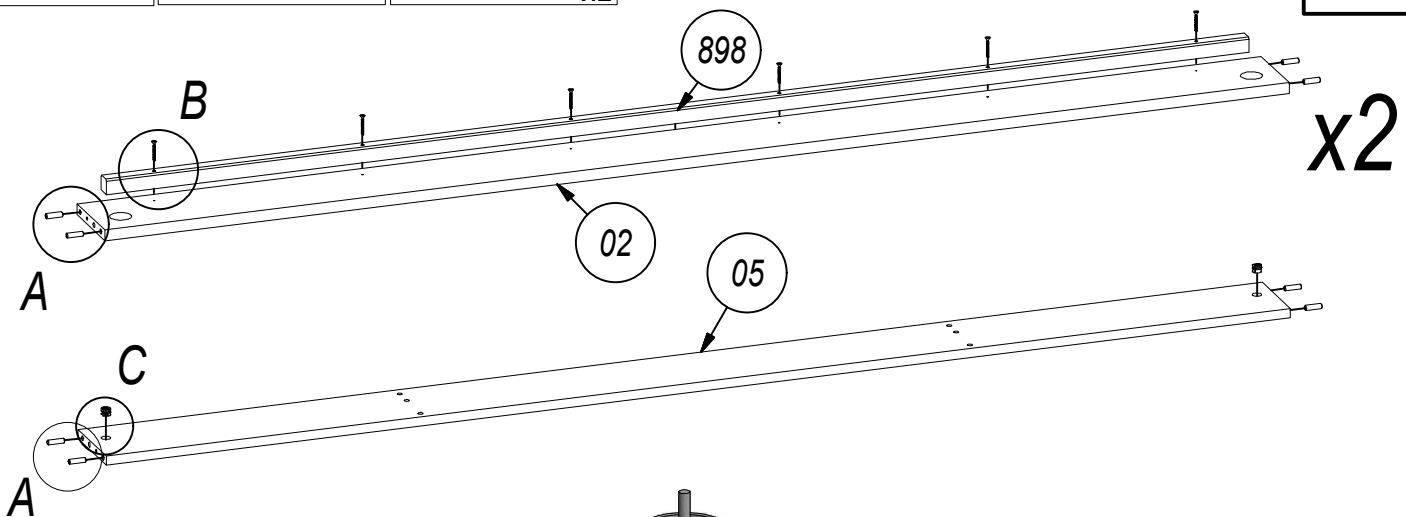

L-11 mm 11809 x2	1305 x6	Ø6x60 154806 x4	L-6 107947 x1	M6x10x13 154808 x4
------------------------	------------	-----------------------	---------------------	--------------------------

18

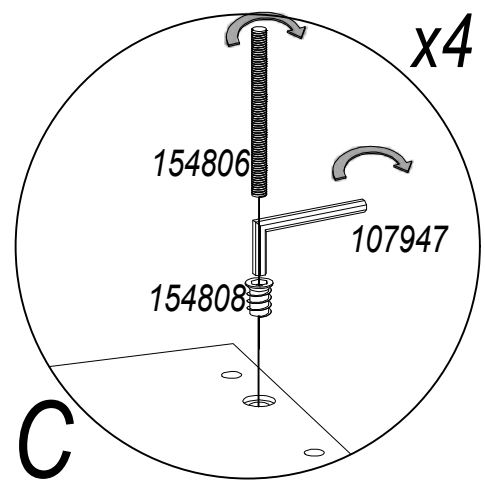
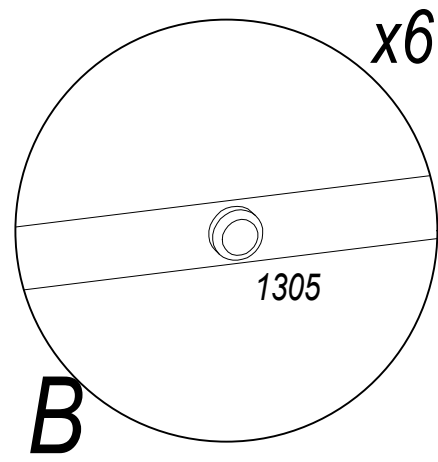
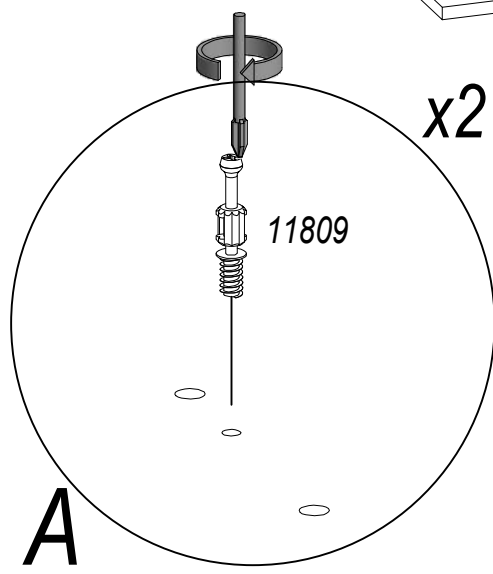
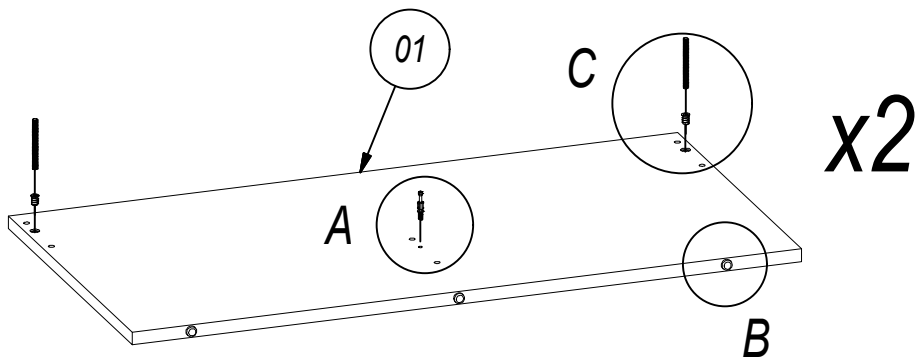

Ø7x50 1354
x8

19

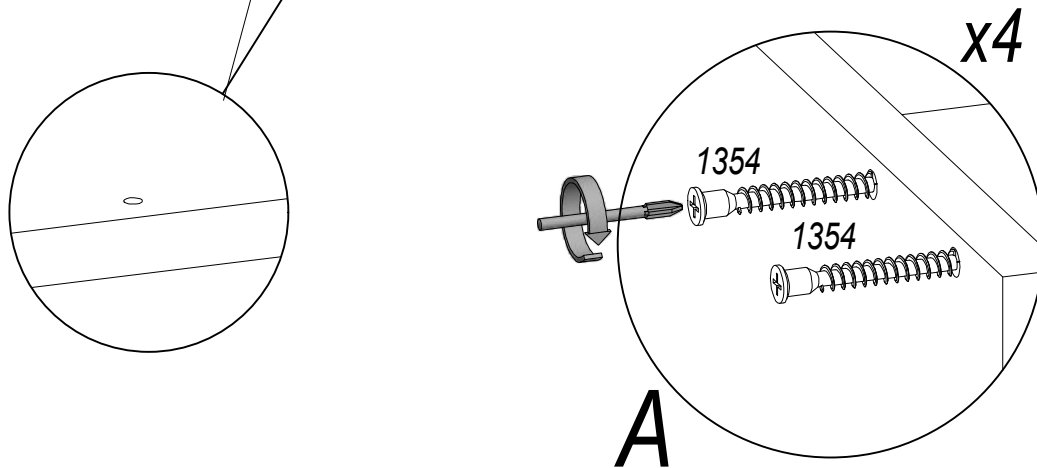
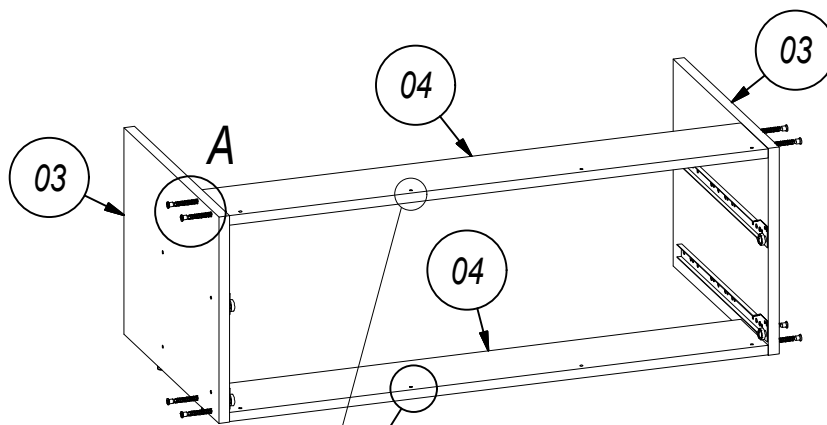

Ø7x50 1354
x2

20

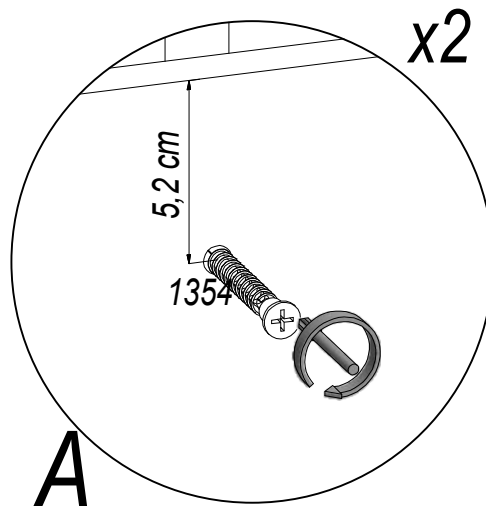
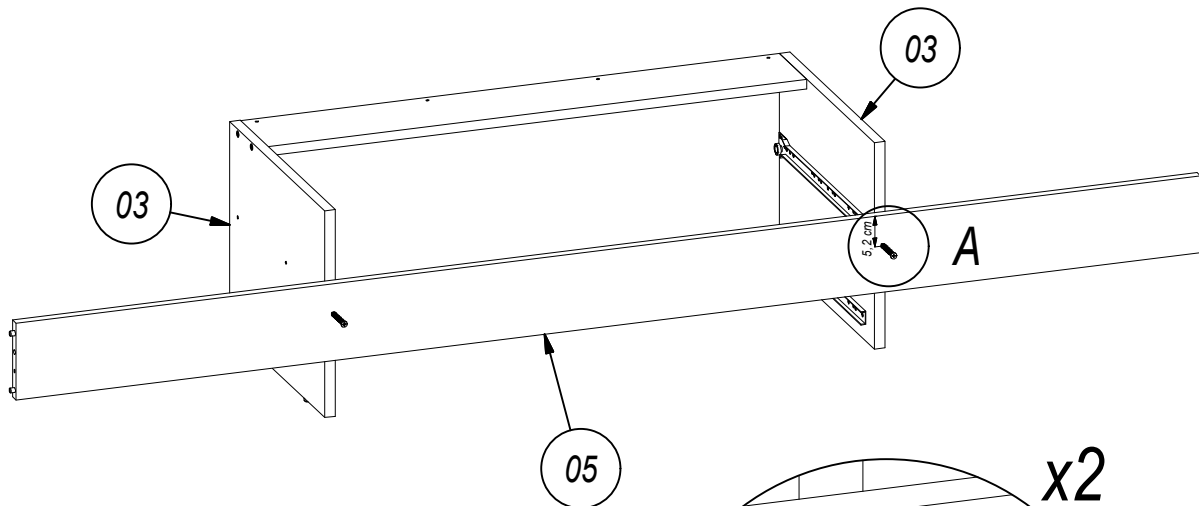

Ø35 154809
x4

21

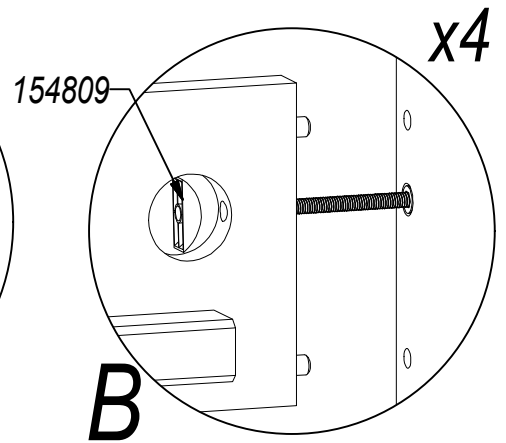
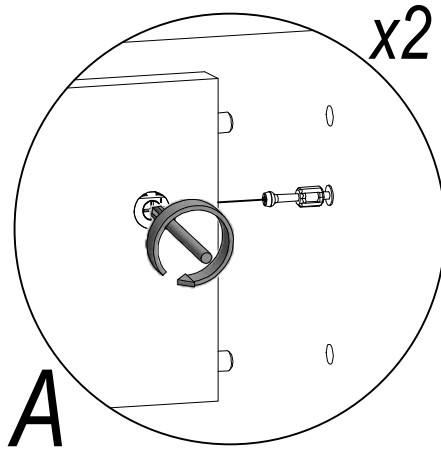
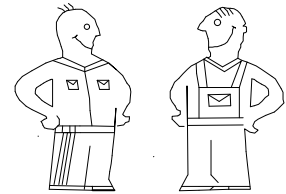
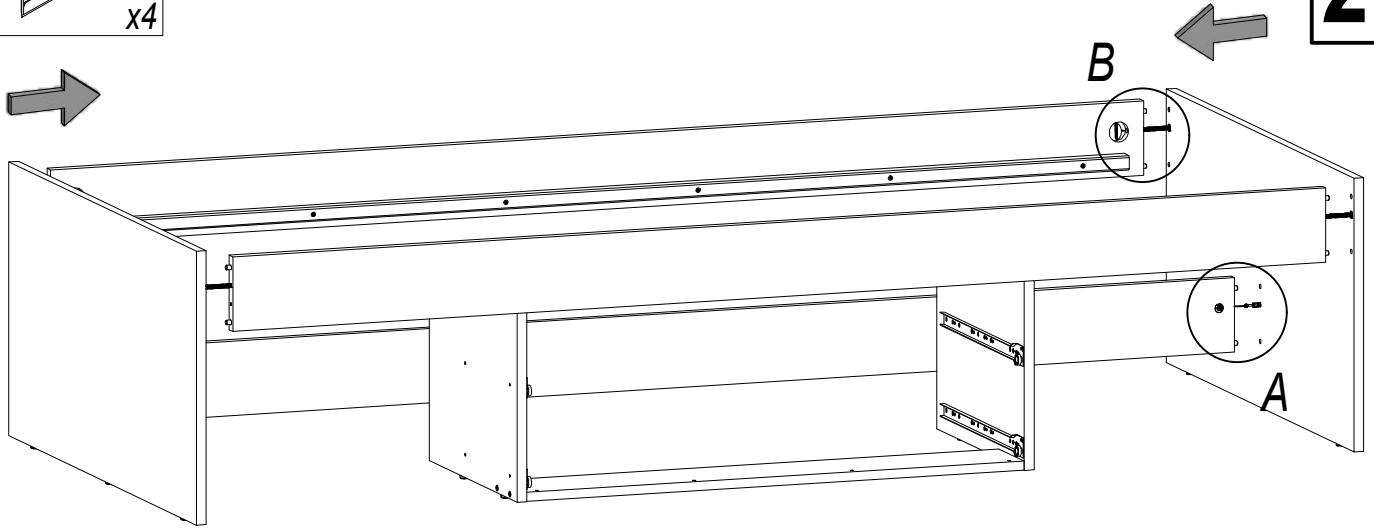

M6 154807
x4

22

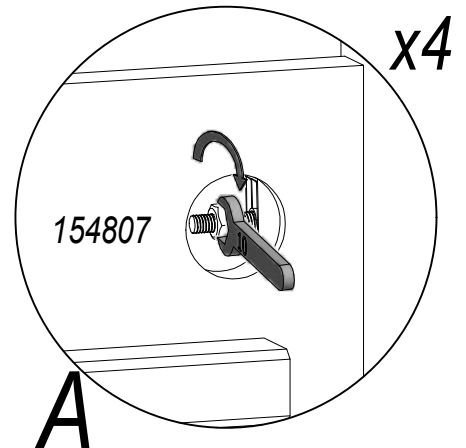
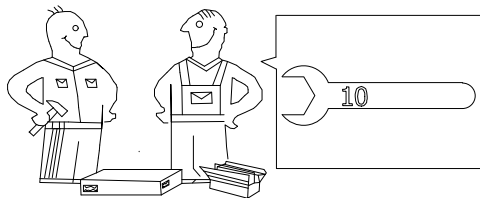
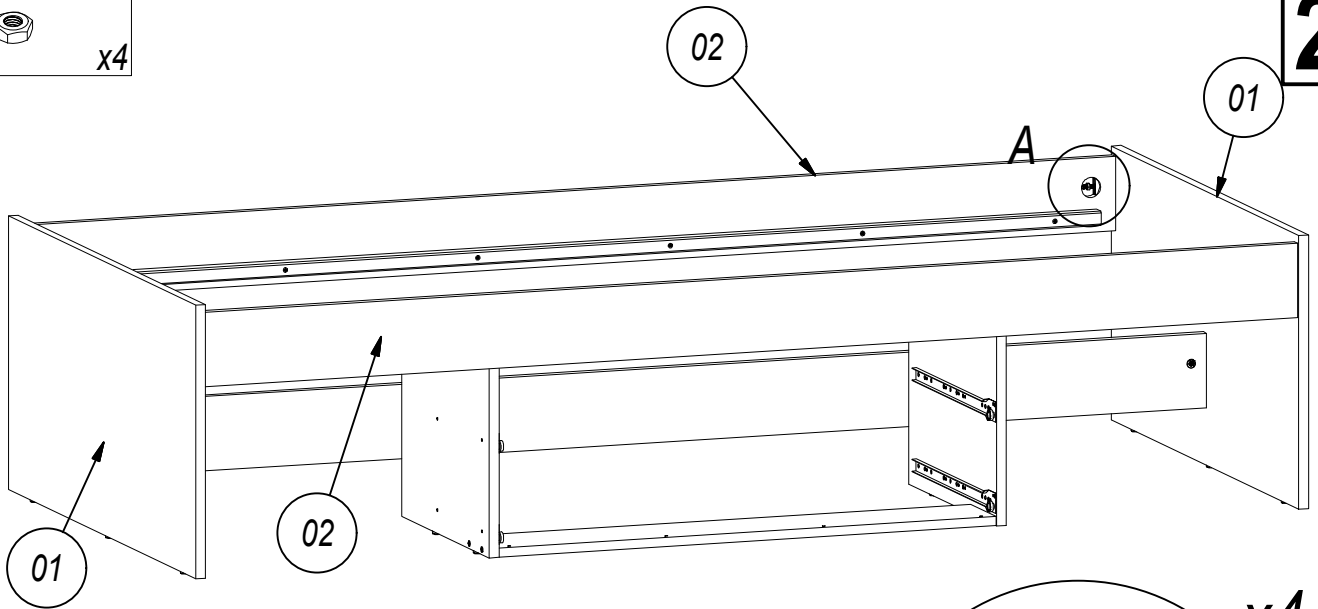

US Ø3,5x13

1011

56590



x8

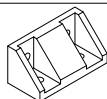

x2

23

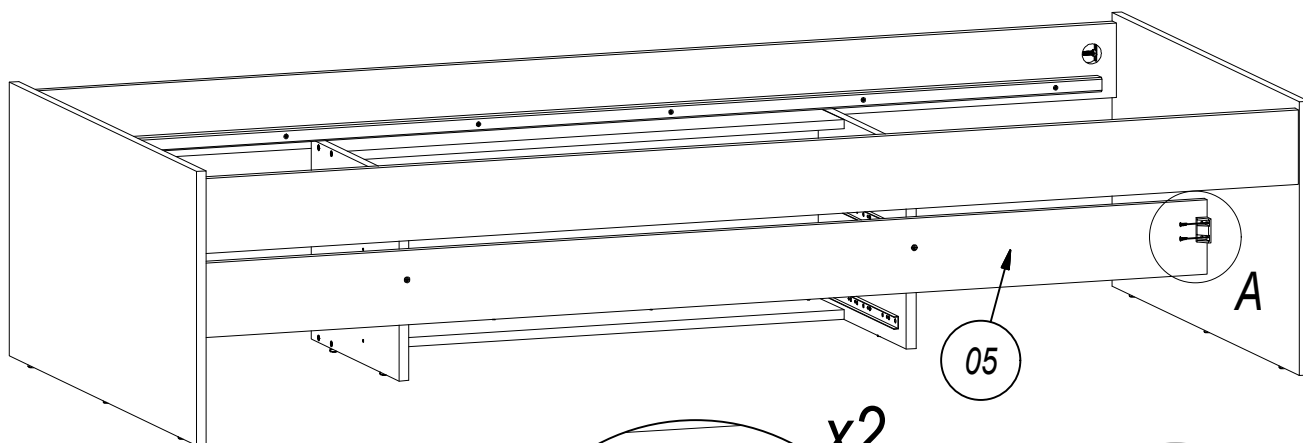

05

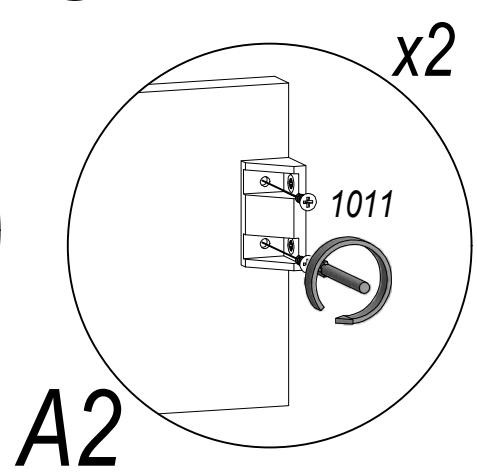
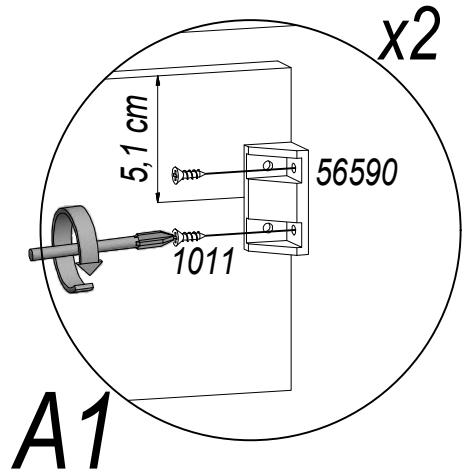

UP Ø4x35

1059



x4

24

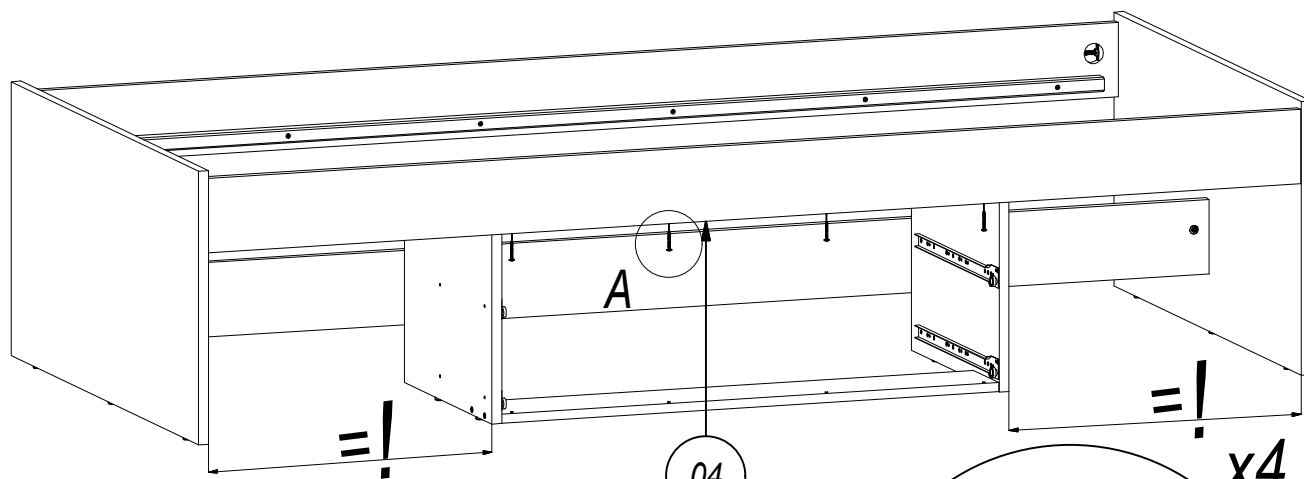

04

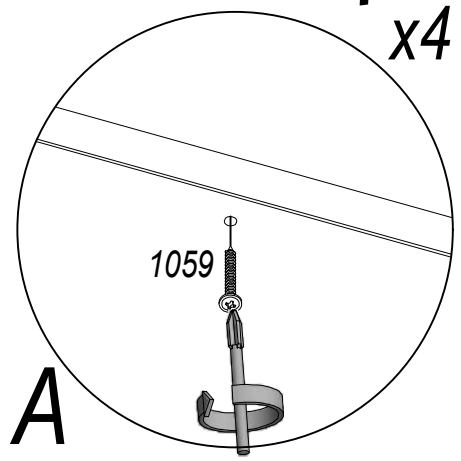

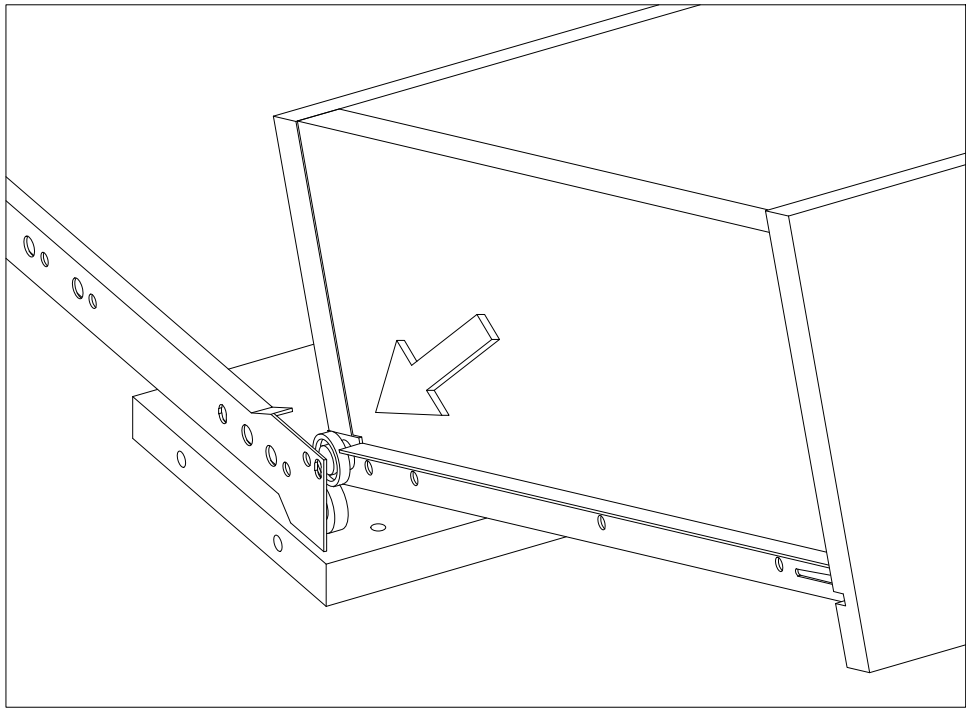

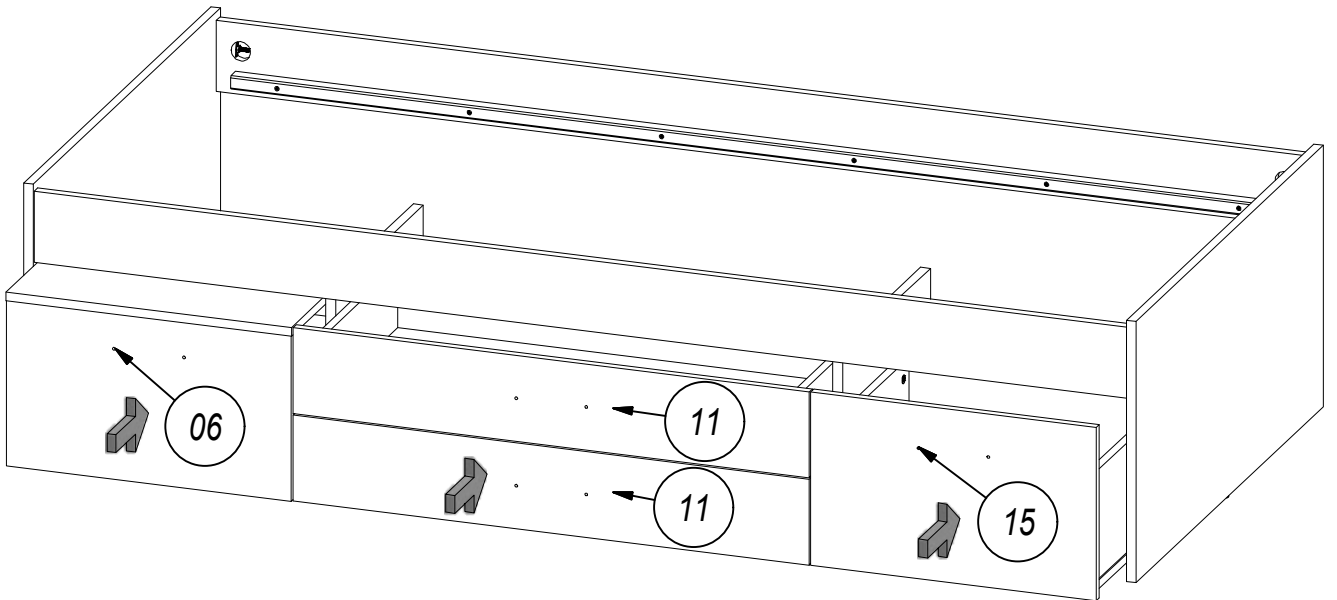

OPTION L

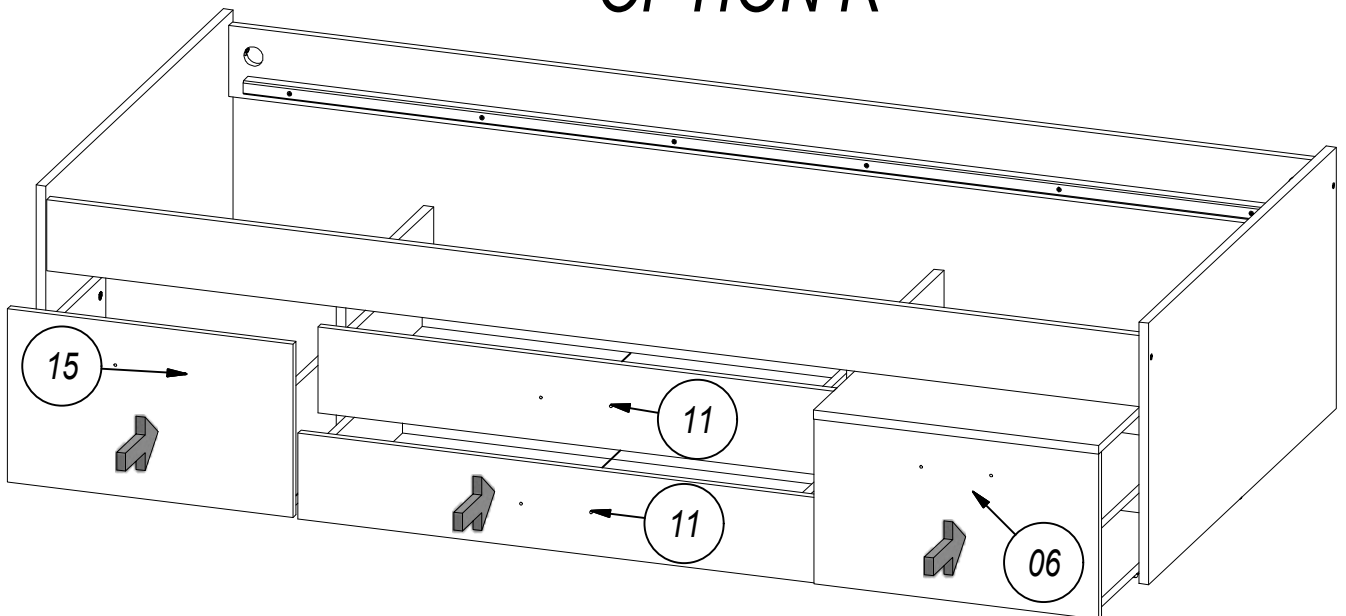

OPTION R

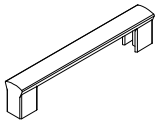

153498  PLASTIC	UP Ø4x30  x8	1012
x4	Ø20  x26	143031

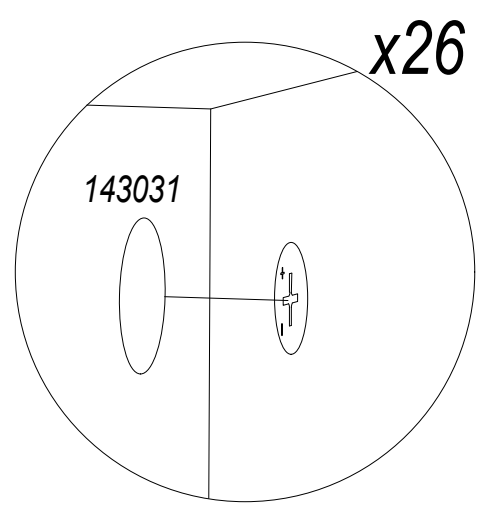
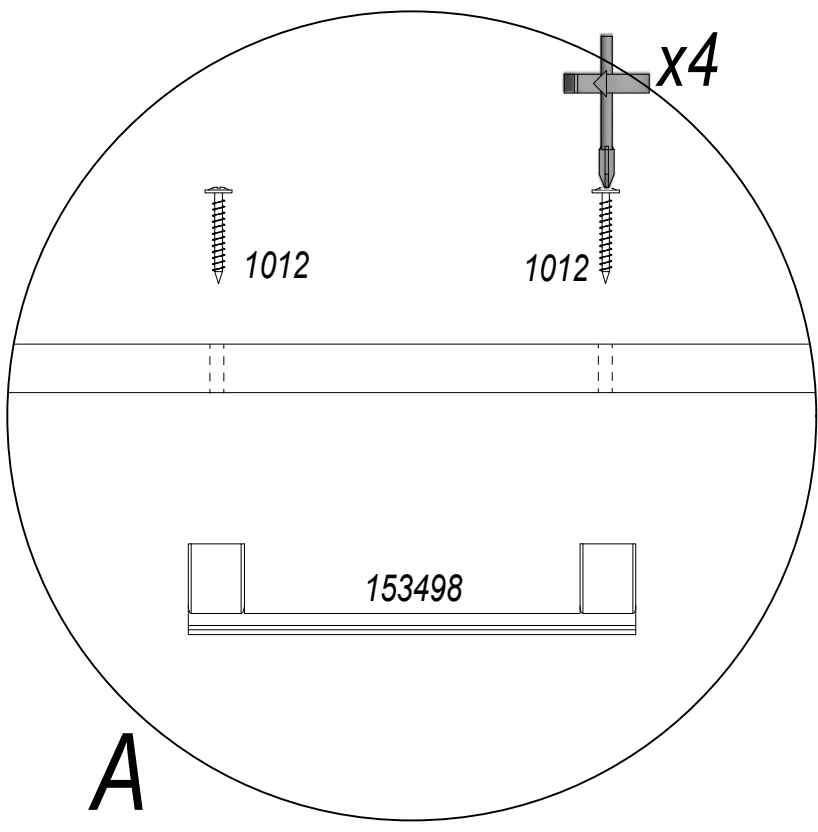
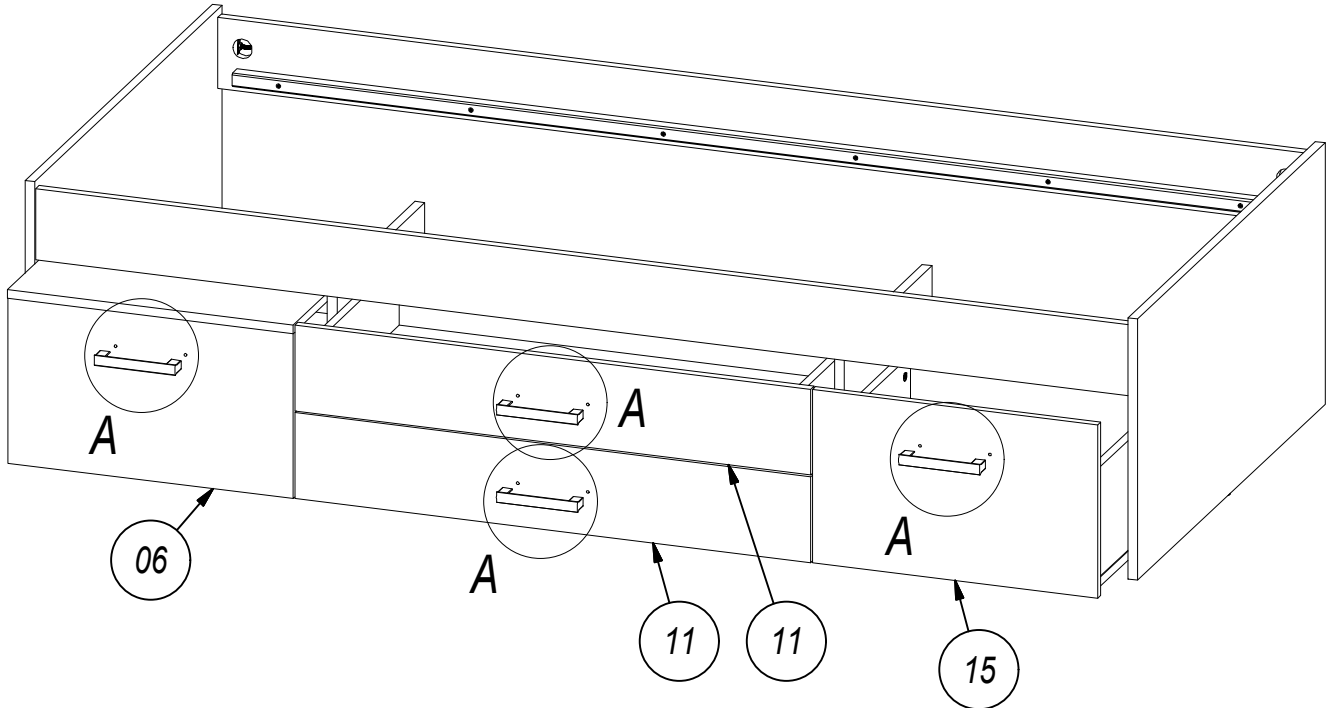

BEANSTANDUNG / COMPLAINT / RÉCLAMATION

Fax + 33 3 88 05 55 68

Finden Sie dieses Formular online / Find this form online / Retrouvez ce formulaire en ligne :



www.interlink-sas.de/Service/Privatkunden-service/Kundendienstsanfrage/

Herr / Mr. / Monsieur Frau / Mrs. / Madame

Vorname / First name / Prénom

Nachname / Last name / Nom

Straße, Hausnummer / Street, Street Number / Numéro, Rue

PLZ / Postal Code / Code Postal

Ort / City / Ville

Land / Country / Pays

Tel.

Mail



Machen Sie es sich einfach!

Scannen Sie mich und füllen Sie das Formular online aus

Make it easy!

Scan me and fill out the form online

Simplifiez-vous la vie!

Scannez-moi et remplissez le formulaire en ligne

1 ARTIKELBEZEICHNUNG / ARTICLE NAME / NOM DU PRODUIT

2 REF. / ART. NR

3 ORDER

Bei welchem Vertriebspartner/Händler wurde der Artikel erworben?
What sales partner/dealer was the article purchased from?
Auprès de quel distributeur ou magasin l'article a-t-il été acheté ?

.....
.....



Bitte wenn möglich Bilder senden
Please send uns pictures if possible
Merci de nous envoyer vos photos
5 MB max.

Für Ihre Mithilfe zur schnellen Bearbeitung Ihrer Reklamation möchten wir uns sehr bedanken.
Thank you very much for assisting us in processing you complaint without delay.
Nous tenons à vous remercier pour votre collaboration au traitement rapide votre réclamation.

Auf der Montage Anleitung / On the assembling instruction / Sur la notice de montage

1 "PASADENA "

Montage Anleitung / Notice de Montage / Assembling Instruction

2 ART. NR: 52 28 71 08

EAN NO.: 40 10 340 87 10 82

3 ORDER: 16916



GRUND DER BEANSTANDUNG / REASON FOR COMPLAINT / MOTIF DE LA RÉCLAMATION

FEHLENDES TEIL / MISSING PART / PIÈCE MANQUANTE

Referenz des Bauteils / Reference of the component / Référence de la pièce

BESCHÄDIGTES TEIL / DAMAGE PART / PIÈCE DÉFECTUEUSE

Referenz des Bauteils / Reference of the component / Référence de la pièce

SONSTIGE / OTHER / AUTRE

In der Montage Anleitung
In the assembling instruction
Dans la notice de montage

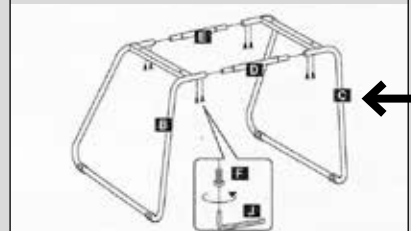

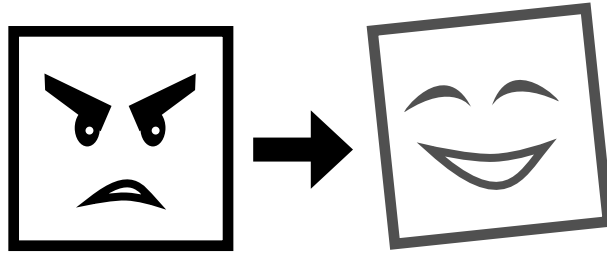

BEANSTANDUNG RECLAMATION COMPLAINT RECLAMO



**Machen Sie
es sich einfach!**

Scannen Sie mich und füllen Sie
das Beanstandungsformular
online aus



**Simplifiez-vous
la vie !**

Scannez-moi et remplissez
le formulaire de réclamation
en ligne



Make it easy!

Scan me and fill out
the complaint form
online



Falla Facile!

Scansionami e
compila il modulo
onlin



Scan me

www.interlink-sas.de/Service/Privatkundenservice/Kundendienstanfrage/

Inter Link traite les données recueillies pour donner suite à votre réclamation et l'amélioration des produits. Pour en savoir plus sur la gestion de vos données personnelles et pour exercer vos droits, reportez-vous à l'information communiquée sur notre site internet à l'adresse suivante : <https://www.interlink-sas.de/fr/Service/Service-clients-particuliers/Demande-service-client/>

INTER LINK, Z. A. du Niederwald
F-67470 Seltz www.interlink-sas.com

 **Inter Link**[®]

WICHTIG • IMPORTANT!

Liebe Kundin, lieber Kunde!

Vielen Dank, dass Sie ein Produkt von Inter Link SA gekauft haben. Jedes Möbel wird mehrfach auf einwandfreien Zustand kontrolliert. Trotzdem kann es vorkommen, dass hin und wieder etwas nicht zu Ihrer Zufriedenheit ist (siehe hierzu auch Rückseite). In einem solchen Fall teilen Sie uns den Grund Ihrer Beanstandung, die Artikel-Nummer und die untenstehende 4-stellige Order-Nummer für das gekaufte Produkt mit. Sie können Ihre Beanstandungen auch auf der Montageanleitung einzeichnen und an uns senden oder faxen.

Bitte geben Sie in jedem Fall die Order-Nummer an, sonst kann Ihre Reklamation nicht bearbeitet werden.
Wir danken Ihnen für Ihr Verständnis und wünschen Ihnen viel Freude mit Ihrem neuen Möbel!

Dear customer!

Thank you for buying a product from Inter Link SA. This piece of furniture has been checked several times for its faultlessness. Unfortunately it is still possible that every now and then something is not quite to your satisfaction (please also see the back-side of this page). In that case you have to state the article number and the four digit order number of the purchased product which you can see at the bottom of this page additionally to your complaint. You can also mark the fault on the assembly instructions and send it to us by fax or post.

Please make sure that you always state the order number, otherwise we cannot process your complaint.
We thank you for your understanding and hope you will enjoy your piece of furniture.

Chère cliente, cher client!

Merci d'avoir acheté un produit de notre gamme. Ce meuble a été plusieurs fois contrôlé lors de sa fabrication. Si toutefois ce produit ne vous donnait pas entière satisfaction, nous vous serions reconnaissant de bien vouloir spécifier, lors de votre réclamation, la référence de l'article et le numéro de commande (Order n°) inscrit en bas de cette page et indiquer le numéro de la pièce défectueuse en vous aidant pour cela de la notice de montage.

Remettez ce document au point de vente où vous avez effectué votre achat qui transmettra.

N'omettez pas d'indiquer le numéro d'order ci dessous, indispensable au bon traitement de votre réclamation.
Nous vous remercions pour votre compréhension.

Link's

Inter Link SA
Z. A. du Niederwald
F-67470 Seltz
Frankreich/France

International:
Telefon: (0033) 3 88 05 55 50
Telefax: (0033) 3 88 05 55 68

National:
Téléphone 03.88.05.55.59
Téléphone 03.88.05.55.77
Télécopie 03.88.05.55.79

e-mail:
service@interlink-sa.com
www.interlink-sa.com

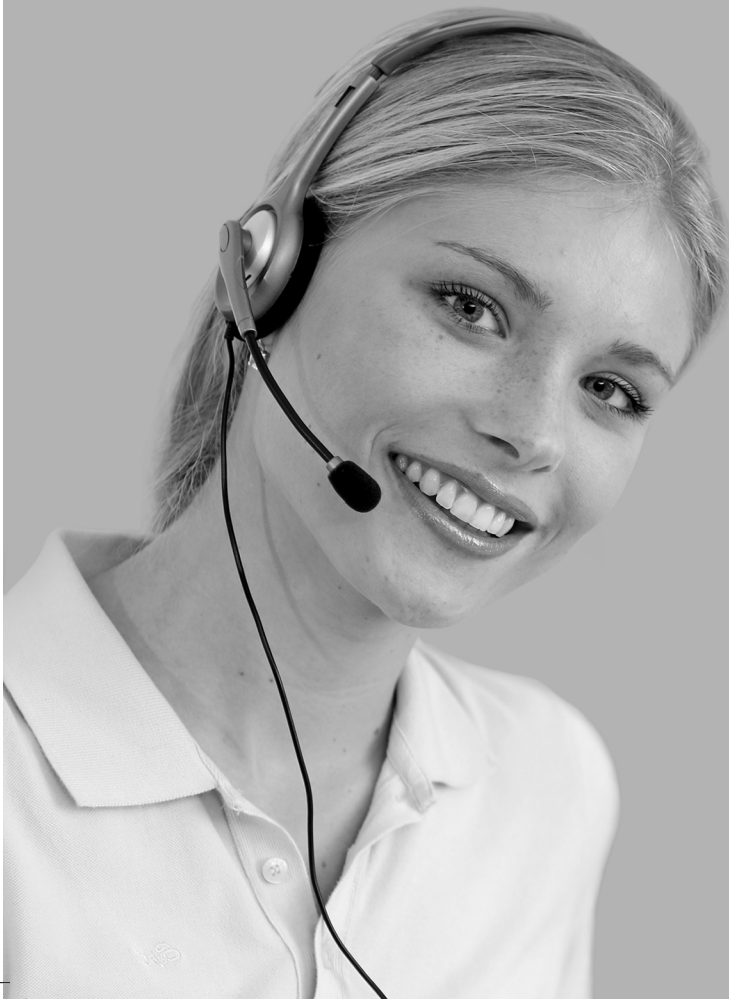

Wir möchten,
dass **Sie** zufrieden sind!

We want **YOU** to be
pleased with our quality!

Nous voulons **VOUS**
donner entière satisfaction !

Order-Nr./Order no./Commande no.

Holz lebt ... — Hinweise zu Ihrem Produkt!

Sie haben sich mit dem Kauf für ein Möbel aus Massivholz, ein Naturprodukt, entschieden. Die Echtheit des Holzes erkennen Sie an der unterschiedlichen Maserung - den so genannten „Jahresringen“ - und den Ästen. Die Jahresringe, teilweise mit ihrer rötlich-braunen Färbung zeigen das Alter des Baumes. Die Natur des Holzes und Ihre vorteilhaften Eigenschaften geben jedem einzelnen Möbelstück Ihren ganz „persönlichen Charakter“ und verleihen jedem Möbel die Bezeichnung „Unikat“.

Auch andere Eigenschaften sollten Ihnen bekannt sein:

Holz kann Wasser und Wärme aufnehmen und auch wieder abgeben, das bedeutet, es passt sich dem Umgebungs-Klima an. Bei feuchtem Klima wird Wasser aufgenommen - das bewirkt, dass das Holz „wächst“ (quillt). Bei sehr trockenem Klima wird Wasser abgegeben und das Holz „schrumpft“ (schrindet). Dieses „Arbeiten“ des Holzes ist naturbedingt und kann Maßveränderungen herbeiführen. Trotz sorgfältiger Qualitäts-Sortierung, können durch nicht sichtbare Verwachsungen und unterschiedliche naturbedingte Maserungsverläufe, Spannungen auftreten, die ein „Verziehen“ (Propeller) bewirken. Bekommen Teile nur einseitig Feuchtigkeit oder Wärme, dies kann auch während des Transportes auftreten, so hat dies zur Folge, dass Teile „schüsseln“ (hohl oder bauchig werden). Um dieses „Schüsseln“ wieder rückgängig zu machen, stellen Sie die hohlen Seiten einige Tage gegeneinander, so dass bei normalem Raumklima die Rückbildung erfolgen kann. Beim oben erwähnten „Arbeiten“ können auch kleine Risse, leichte Unebenheiten, leichte Aufrauungen auf der Oberfläche und an den Kanten auftreten. Äste und Verwachsungen, unterschiedlich starke Maserungen, und Farb-/Struktur-Unterschiede sind demzufolge positive Unikats-Merkmale eines völlig natürlich gewachsenen Werkstoffes und stellen keine Beanstandungen/Reklamationen dar.

Um die Oberfläche des Holzes zu schützen und das natürliche Aussehen zu erhalten, wurde sie mit einem klaren Schutzlack überzogen. Sofern Sie ein gebeiztes Möbel erworben haben, sind eventuelle Farbschwankungen naturbedingt, und verleihen dem naturbedingten Unikat seine ganz persönliche Note. Massivholz nimmt Beize je nach Holzmaserung unterschiedlich stark auf. Diese natürlichen Abweichungen in der Beiztonintensität stellen keine Beanstandung dar.

Um die Auswirkungen der aufgeführten Eigenschaften so gering wie möglich zu halten, achten Sie darauf, dass die Möbelteile immer in einem normalen Raumklima (ca. 20 - 22 °C und 40 - 50 % Luftfeuchtigkeit) gelagert oder aufgestellt sind.

Pflegehinweis:

Holz, Glas, Stahlmöbel oder MDF und beschichtete Oberflächen: Pflegen Sie Ihr Möbel am besten mit einem leicht angefeuchtetem Staubtuch oder mit etwas Möbelpolitur (im Handel überall erhältlich und beachten Sie unbedingt die Gebrauchsanweisungen dazu). Wenn Sie Ihr Möbel gelegentlich feucht abwischen, vergessen Sie bitte nicht mit einem trockenen, weichen Tuch nach zu reiben.

Stahlmöbel: Das Metall ist in der Oberfläche mit einer Schutzlackierung versehen. Diese kann durch die maschinell bedingte Produktion evtl. kleine Farbdifferenzen, Wolken, Flecken aufweisen, welche keinen Reklamationsgrund darstellen. Falls durch den Transport evtl. einige Metallteile etwas verbogen sein sollten, können Sie diese vorsichtig in die Ursprungslage zurückbiegen. Die Schrauben wollen Sie bitte nicht überdrehen und von Zeit zu Zeit nachziehen.

MDF und beschichtete Oberflächen: MDF besteht aus Holzfasern. Die beschichtete Oberfläche bitte nicht mit Messer oder spitzen Gegenständen bearbeiten, da hier Schäden entstehen können. Dadurch verursachte Schäden sind keine Reklamationsgründe.

Sollten evtl. durch die maschinelle Bearbeitung der beschichteten Kanten oder Oberflächen, die Kanten oder Ecken etwas scharfkantig sein, können sie diese mit einem handelsüblichen Sand-Schleifpapier nachschleifen. Gehen sie jedoch dabei sorgfältig und vorsichtig vor, damit nicht zu viel Material entfernt wird.

**Wir wünschen Ihnen viel Freude mit Ihrem neuen Möbel
Ihr Qualitätssicherungsteam bei Inter Link SA**

Le bois, une matière vivante... Indications sur votre produit :

Avec l'achat de ce meuble en bois massif, vous avez fait l'acquisition d'un produit naturel. Vous reconnaissez l'authenticité du bois grâce aux différentes veines appelés aussi cernes, ainsi qu'aux nœuds. Les cernes partiellement teintés de rouge-brun, indiquent l'âge de l'arbre. La nature du bois et ses propriétés avantageuses donnent à chaque meuble un caractère personnel et prêtent ainsi la désignation de „pièce unique“ à chacun d'eux.

Mais bien d'autres éléments sont à porter à votre connaissance :

Le bois peut absorber l'eau et la chaleur et les rejeter, ce qui signifie qu'il s'adapte à tous les climats. Dans un milieu humide, il absorbe l'humidité ce qui cause des variations dimensionnelles (gonflement) du bois. Dans un milieu sec, le bois s'assèche et entraîne des variations dimensionnelles inverses. Ce „travail“ du bois est un phénomène naturel mais peut ainsi provoquer des modifications de mesures. Malgré un tri soigneux et qualitatif, des cicatrices non visibles et des cours de veines différents dus aux effets naturels du temps peuvent provoquer des fissures ou éclatements (souvent en forme d'étoile). Une exposition unilatérale à l'humidité ou la chaleur peut causer faire goger ou voiler le bois. Si certaines pièces devaient être goge ou voilé, il vous suffit de les poser l'une contre l'autre pendant quelques temps afin qu'elles reprennent leur forme initiale. Dans le „travail“ du bois décrit précédemment, de petites fissures, inégalités ou rugosités peuvent également apparaître sur les parties extérieures de votre meuble. Nœuds, cicatrices, cernes de structure ou de couleur différentes sont considérés comme les signes particuliers d'une matière totalement naturelle et ne peuvent par conséquent être sujet à réclamation.

Pour protéger la surface du bois et conserver son aspect naturel, celle-ci est recouverte d'un vernis de protection, transparent. Dans la mesure où vous avez acquis un meuble de teinte miel, des variations de couleurs sont dues aux effets naturels du bois, ce qui accentue sa note personnelle de pièce unique. Le bois massif absorbe plus ou moins fortement la teinture ce qui ne peut être un motif de réclamation. Afin de réduire au maximum les conséquences citées ci-dessus, veuillez à ce que votre meubles soient entreposés dans un climat ambiant normal d'environ 20-22°C et d'une hygrométrie de 40 à 50 %.

Conseils d'entretien

Pour tous les meubles en bois, métal, MDF ou panneaux de particules : Nettoyer vos meubles avec un chiffon doux humide ou du produit à bois (disponible dans les magasins spécialisés - lire attentivement la notice d'emploi avant utilisation). Repasser impérativement un chiffon doux et sec.

Meubles en métal : la surface du métal est recouverte d'un laquage de protection. De par la fabrication mécanique, des nuances de teintes peuvent apparaître, celles-ci ne peuvent être prise en compte comme motif de réclamation. Ne pas faire forer les vis, il est préférable de les resserrer de temps en temps.

Meubles en MDF ou panneaux de particules : Les meubles en MDF se composent de fibres de bois recouvertes d'un film. Il ne faut en aucun cas utiliser d'objet pointu ou tranchant sur ces surfaces. Les dommages dus à ces effets ne pourront faire l'objet de réclamations.

Si toutefois les arêtes devaient être vives, il suffit de les poncer légèrement avec du papier émeri fin. Mieux vaut renouveler l'action une seconde fois, de façon à ne pas endommager le meuble.

**Nous vous souhaitons beaucoup de plaisir au montage de votre nouveau meuble.
Cordialement, l'équipe du service qualité chez Inter Link S.A.**

Wood lives ... Important information on your product!

You have decided to buy a furniture of solid wood – a natural product. You can observe the wood genuineness through the knots and the several grains, which are called „Years Rings“. The „Years Rings“ which partially have a red-brownish colour show you the age of a tree. The wood nature and its advantageous features lend each piece of furniture a conotation of an uniqueness.

We would like to inform you about further characteristics of the wood:

Wood can retain and release water and heat - what means that the wood modifies itself according to the environment conditions and weather. If the weather is humid the wood absorbs water and expands. On the contrary, if the weather is dry, the wood releases water and it shrinks automatically. The alterations in the wood depend on the climate and can affect the dimensions of your piece of furniture. Although the woods quality is chosen carefully, the alterations in the wood can lead to strains due to invisible connotation or natural grown runs of grains. If a piece of furniture is exposed to humidity on one of its sides (what can happen during transport as well) this side can warp becoming a concave or convex surface. To obtain the usual and correct form of your piece of furniture, you can set convex sides against each other for some days and store them in a room with room normal room temperature and humidity. The wood will recede and obtain the former shape again. If your piece of furniture has expanded or shrunk for one of the reasons mentioned above, some small cracks, light scratches or unevenness can appear on the surface or edges of the your piece of furniture. Nodes, intergrowths, different runs of grains, colour, and variety of composition are signs for unique features of a natural grown material. This should be no reason for an objections or complaints.

Your piece of furniture is covered with a light varnish layer used to protect the wooden surface and its natural appearance. Since you have bought a stained piece of furniture you should be aware of eventual colour variation caused by the nature of the wood. Solid wood absorbs the stain according to its grains and therefore you will have different colours in your piece of furniture, what should not be a cause of objections or complaints.

To reduce the effect of the characteristics listed, you should pay attention to the room temperature and humidity. Solid wood furniture have to be stored or kept in a room with a temperature between 20 - 22°C and air humidity between 40 - 50 %.

Maintenance advice:

You should clean your piece of furniture with a moistened cloth or with special furniture polish available in supermarkets or specialized stores. Using a furniture polish pay attention to its instructions for use. Please do not forget to wipe your piece of furniture up with a dry cloth.

**We wish you a lot of joy and pleasure with your new piece of furniture.
Your quality assurance team at Interlink**