

Matts 3 in 1

Montage Anleitung / Notice de Montage / Assembling Instruction

ART. NR: 99 80 06 70

EAN NO.: 40 10 340 99 86 73

ORDER

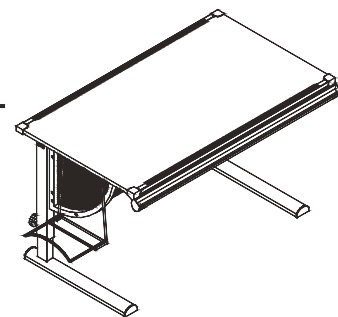

DE Wichtige Montage – Tipps hier zum herunterladen:

SE Viktiga monterings tips att ladda ner här:

EN Important assembly tips to download here:

NO Viktige monterings tips å laste ned her:

FR Conseils de montage importants - à télécharger ici :

FI Tärkeitä asennusvinkkejä ladattavaksi täältä:

IT Suggerimenti importanti per il montaggio da scaricare qui:

HU Fontos szerelési tippek itt tölthetők le:

CZ Důležité montážní tipy ke stažení zde:

EE Siit allalaadimiseks vajalikud olulised näpunäited

PT Dicas importantes de montagem para baixar aqui:

SL Pomembne nasvete za montažo, ki jih lahko prenesete tukaj:

ES Consejos de montaje importantes para descargar aquí:

RS Важне савете за монтажу преузмите овде:

PL Ważne wskazówki montażowe do pobrania tutaj:

RU Важные советы по сборке, которые можно скачать здесь:

NL Belangrijke montagetips om hier te downloaden:

TR Buradan indirmek için önemli montaj ipuçları:

SK Dôležité montážne tipy na stiahnutie tu:

GR Σημαντικές συμβουλές συναρμολόγησης για λήψη εδώ:

BG Важни съвети за сглобяване, които да изтеглите от тук:

LT Svarbūs surinkimo patarimai, kuriuos galite atsisiųsti čia:

RO Sfaturi importante de asamblare pentru descărcare aici:

LV Svarīgi montāžas padomi, ko lejupielādēt šeit:

HR Ovdje možete preuzeti važne savjete za montažu:

LU Wichtig Assemblée Tipps fir hei erofzelueden:

DK Vigtige monterings tips til download her:

ARB صائح مهمة حول التجميع للتنزيل من هنا:



Matts 3 in 1



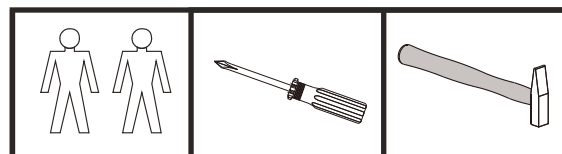
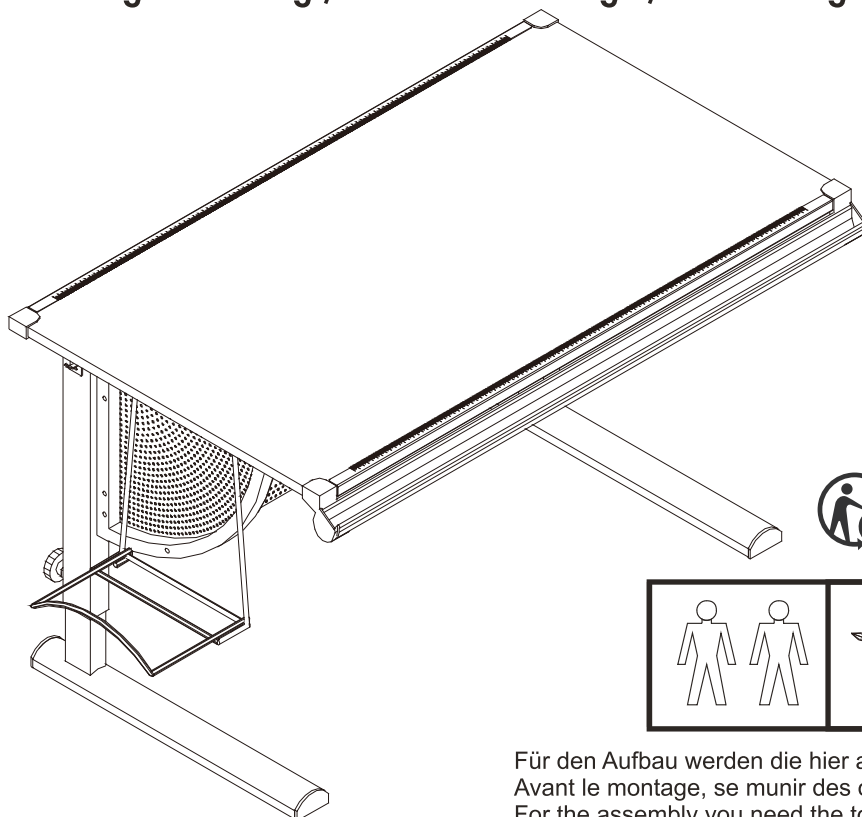



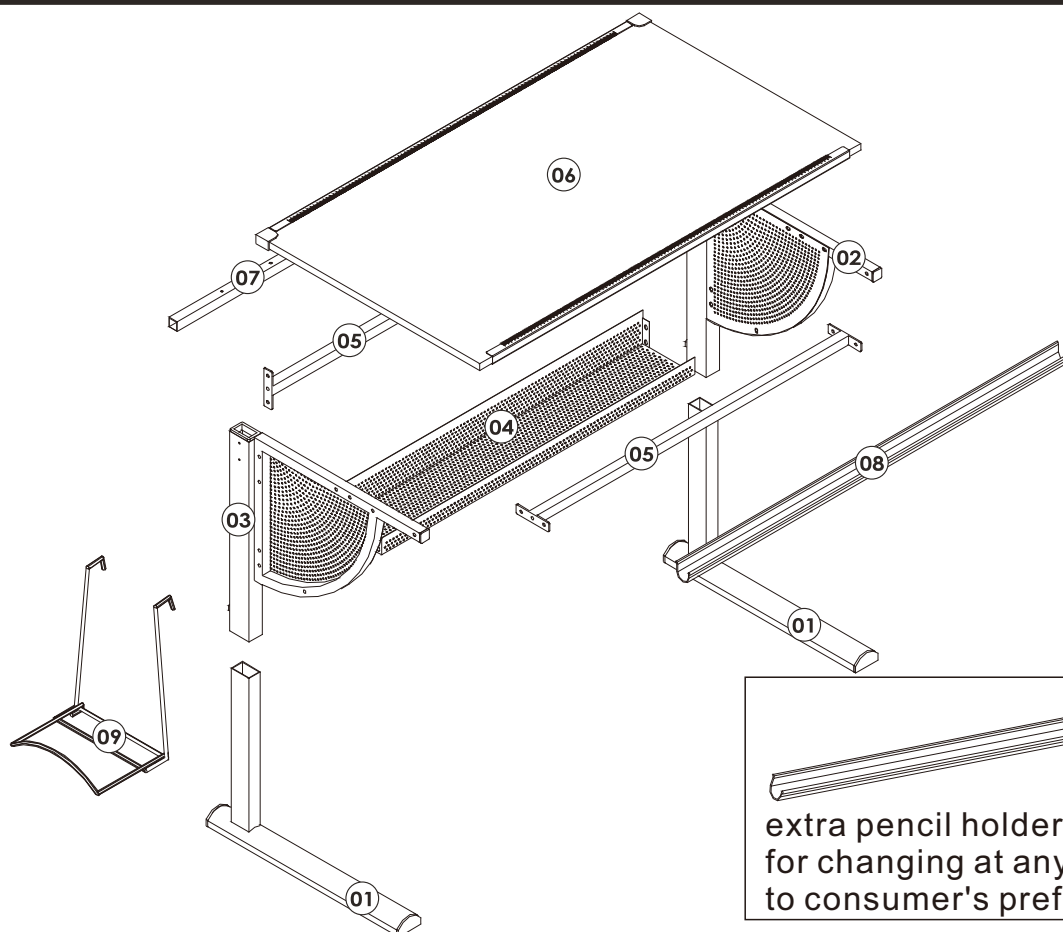







Montage Anleitung / Notice de Montage / Assembling Instruction











Für den Aufbau werden die hier abgebildeten Werkzeuge benötigt.
Avant le montage, se munir des outils nécessaires.
For the assembly you need the tools shown above.



extra pencil holders x 2 pcs are
for changing at anytime subject
to consumer's preference

A		M5x12	02
B		M4x16Long	20
C		M6X12	02
D		M6x15	02
E		M4x35Long	06
F		M6x32	06
G		M6x35	10
H		M6X45	02
I	 Metal	13X1	30
J	 Metal	15X2	04
K	 PVC	17X2	04
L		M6X10	02
M		M6X10	16
N		M6X10	04

O		M16x53	02
P			02
Q			01
R			02
S			02
T			01
U			01
V			01
W			01

01

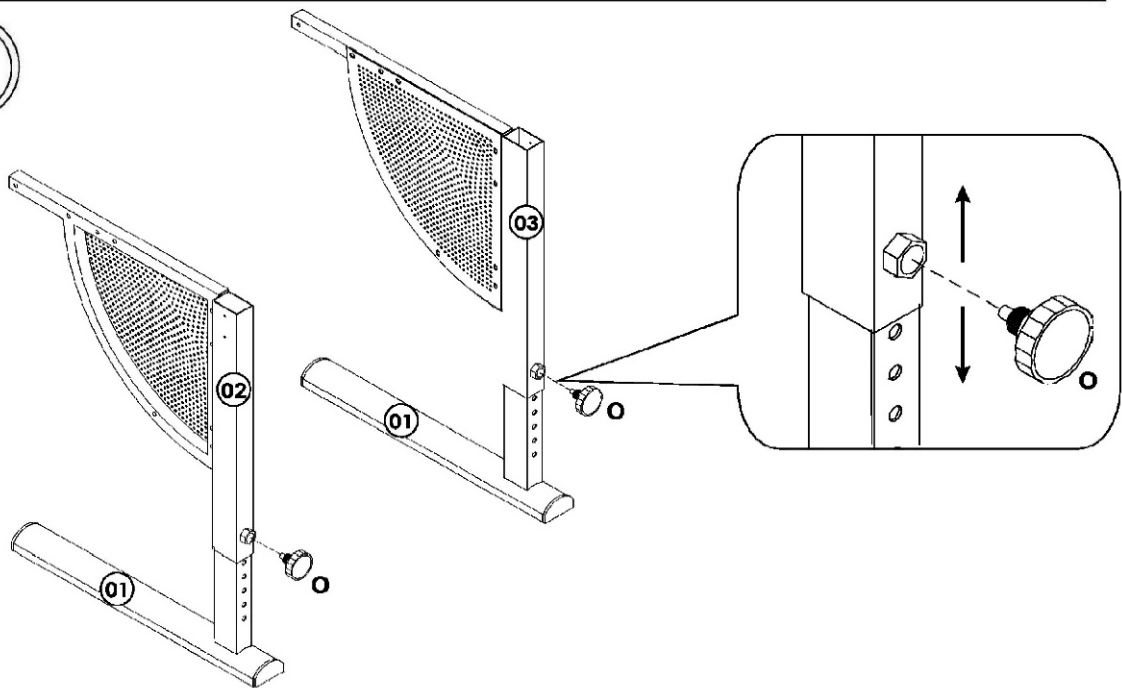

Achtung

Das Lochblech der Seitenwand 2 und 3 muss bei der Montage nach innen zeigen!



Warning

The perforated plate from part 2 and 3 must show to inner side during assembling!



Attention

Le plateau en métal du nur lateral 2 et 3 doit être bourné vers l'intérieur lors du montage!

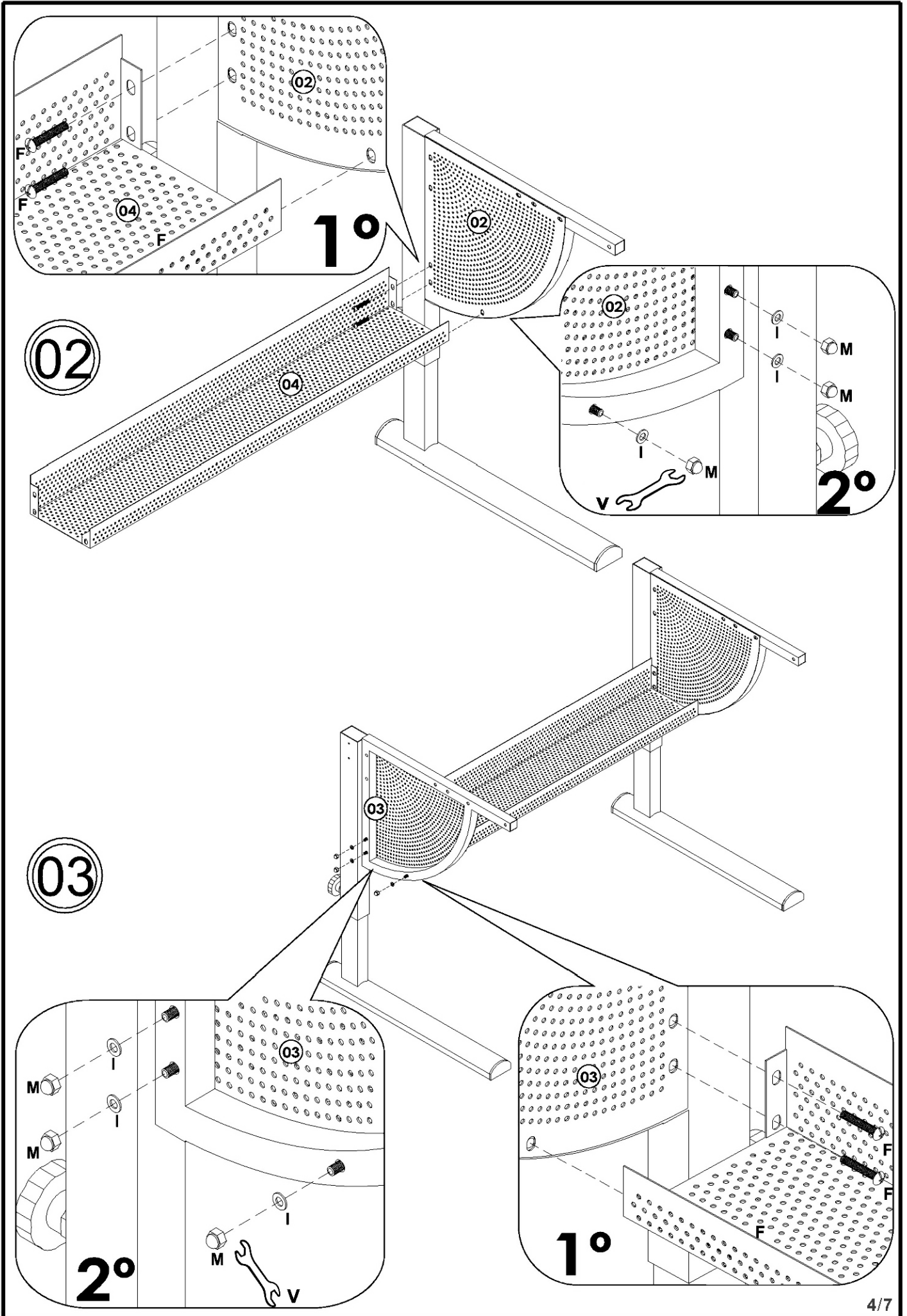

06

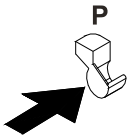
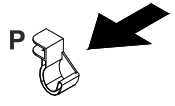

07

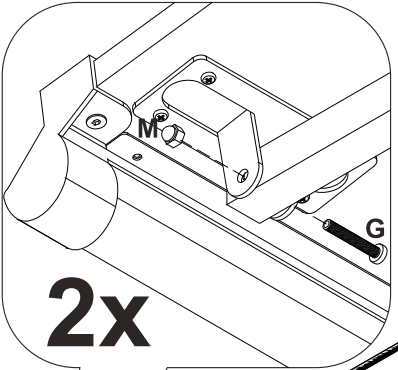
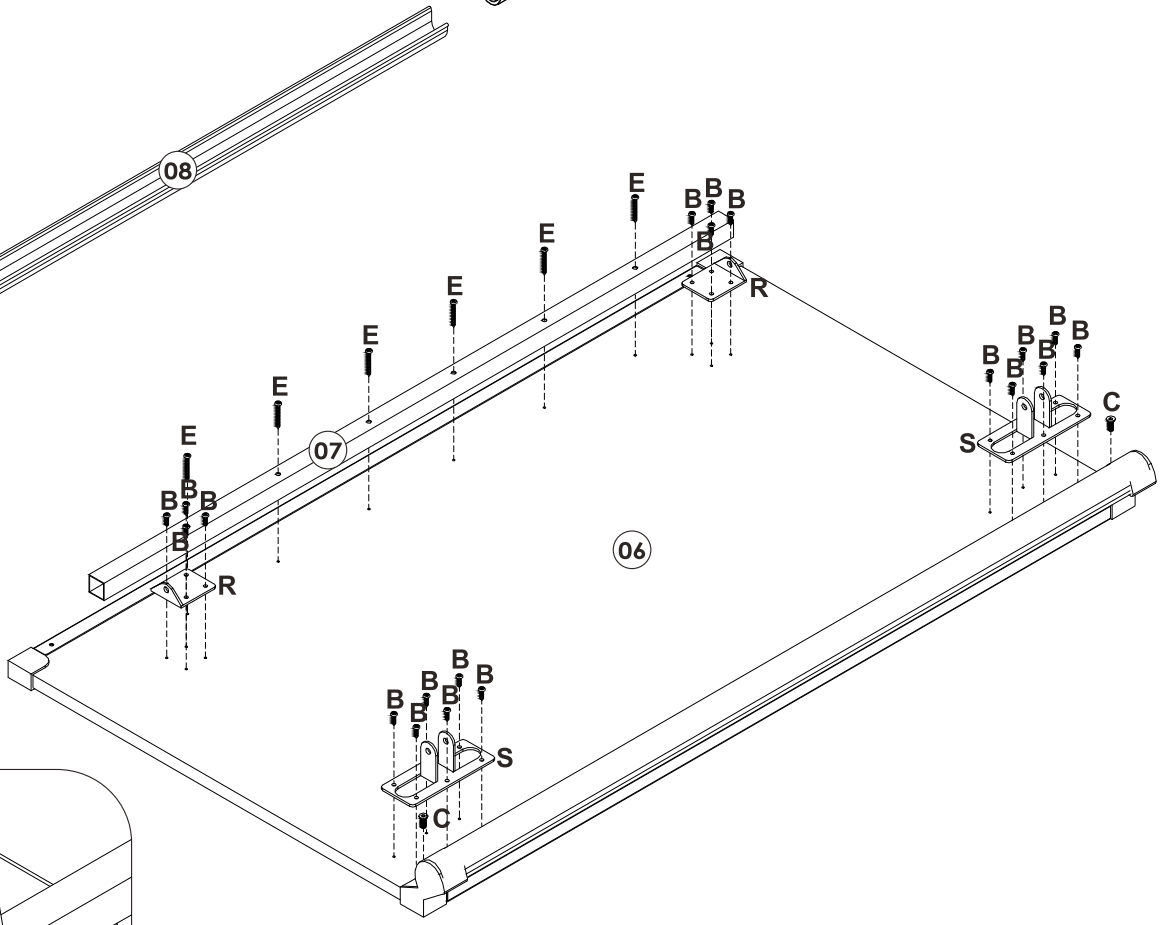

08

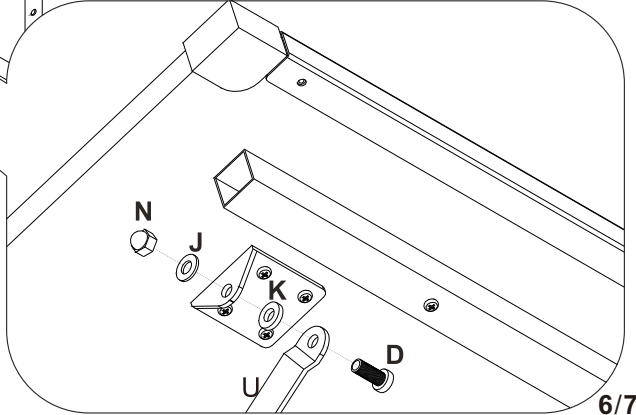
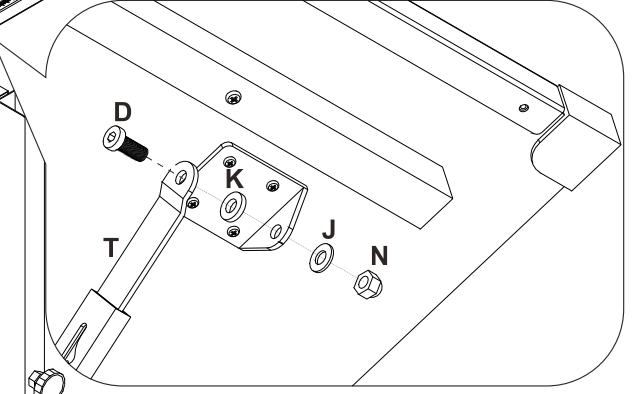
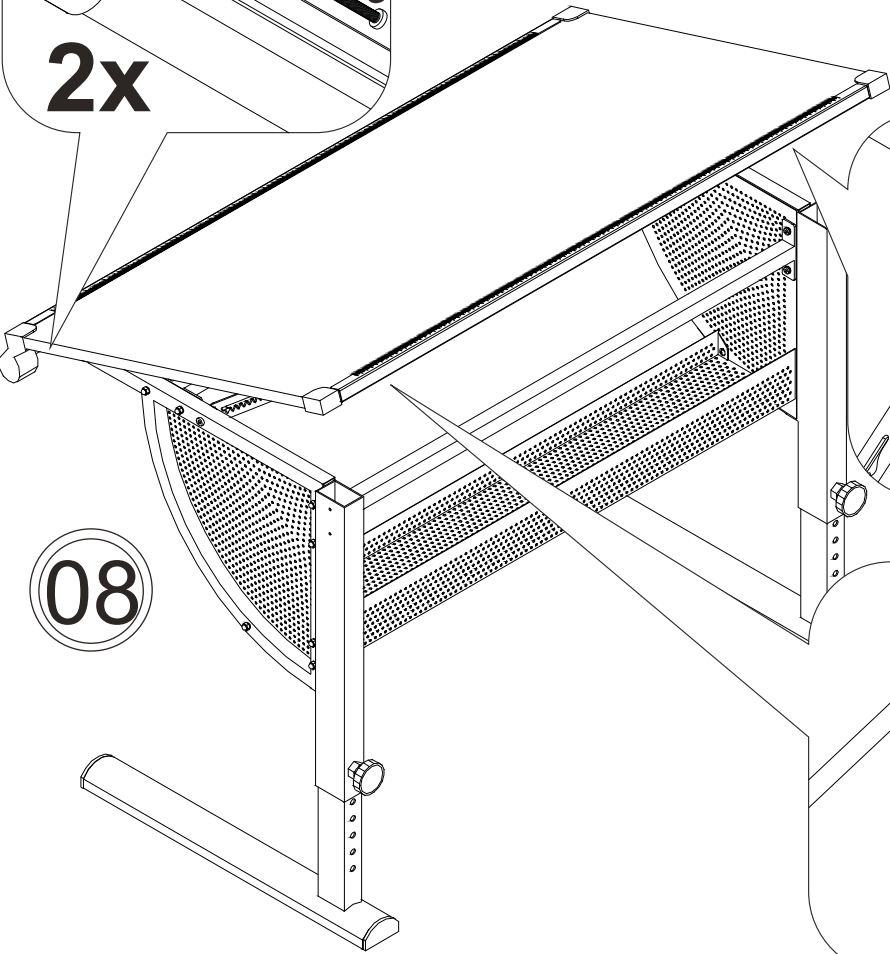

09

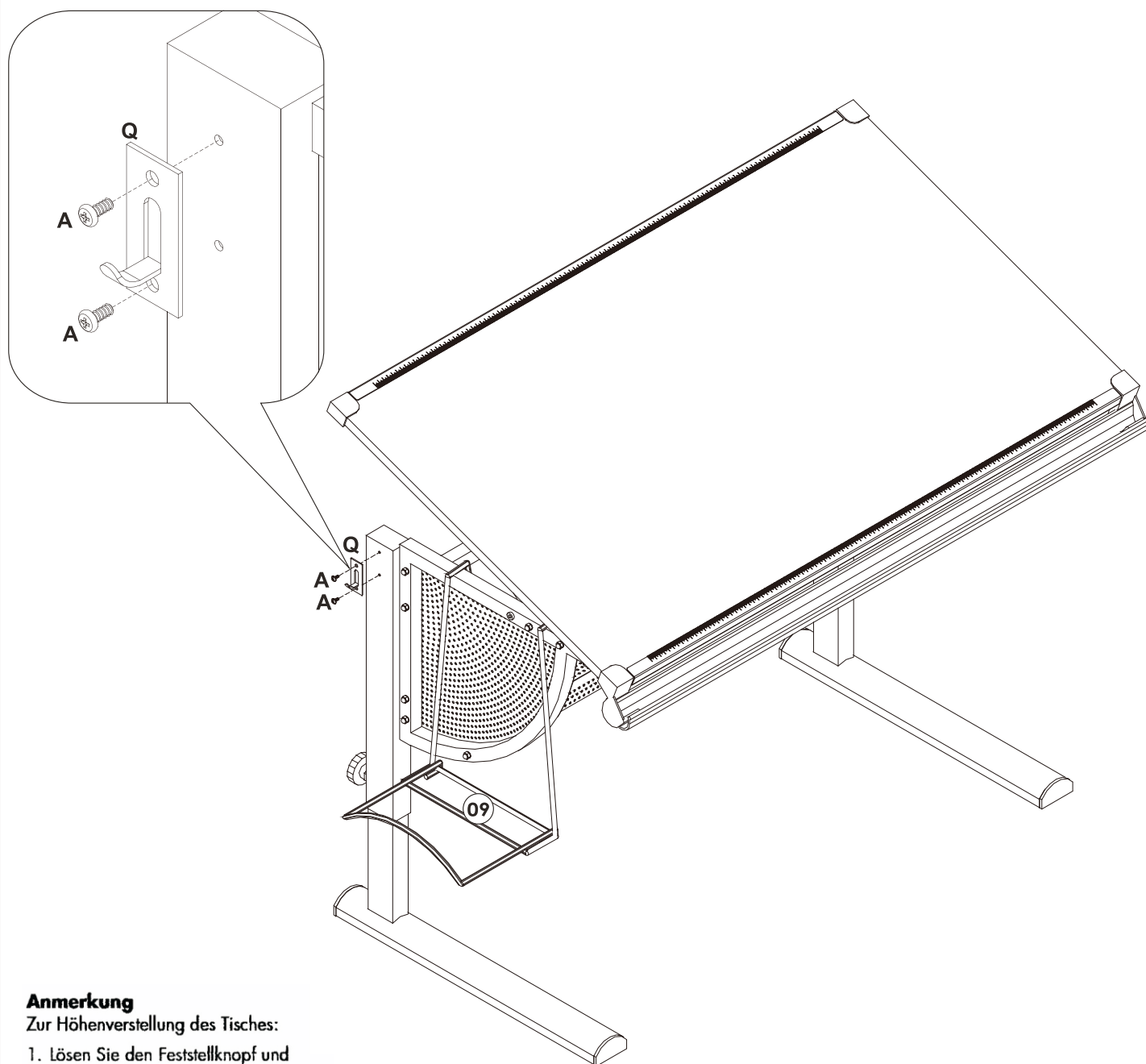

Anmerkung

Zur Höhenverstellung des Tisches:

1. Lösen Sie den Feststellknopf und ziehen Sie ihn heraus.
2. Stellen Sie die gewünschte Höhe ein.
3. Lassen Sie den Feststellknopf in der gewünschten Position einrasten und drehen Sie ihn fest.

Notice

To adjust the height:

1. Unscrew the knob and pull it.
2. Adjust the desired height.
3. Tighten the knob.

Remarque

Pour régler le plateau en hauteur:

1. Dévissez légèrement le bouton et tirez-le vers vous.
2. Réglez le plateau à la hauteur désirée.
3. Relâchez le bouton et revissez-le.