

SKALARE

Montage Anleitung / Notice de Montage / Assembling Instruction

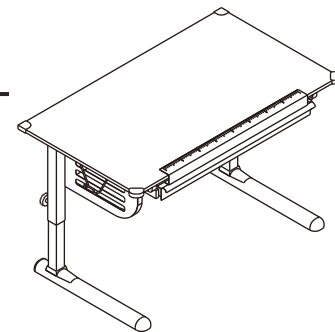

ART. NR: 99 80 06 95

EAN NO.: 40 10 340 98 69 53

ORDER

DE Wichtige Montage – Tipps hier zum herunterladen:

SE Viktiga monterings tips att ladda ner här:

EN Important assembly tips to download here:

NO Viktige monterings tips å laste ned her:

FR Conseils de montage importants - à télécharger ici :

FI Tärkeitä asennusvinkkejä ladattavaksi täältä:

IT Suggerimenti importanti per il montaggio da scaricare qui:

HU Fontos szerelési tippek itt tölthetők le:

CZ Důležité montážní tipy ke stažení zde:

EE Siit allalaadimiseks vajalikud olulised näpunäited

PT Dicas importantes de montagem para baixar aqui:

SL Pomembne nasvete za montažo, ki jih lahko prenesete tukaj:

ES Consejos de montaje importantes para descargar aquí:

RS Важне савете за монтажу преузмите овде:

PL Ważne wskazówki montażowe do pobrania tutaj:

RU Важные советы по сборке, которые можно скачать здесь:

NL Belangrijke montagetips om hier te downloaden:

TR Buradan indirmek için önemli montaj ipuçları:

SK Dôležité montážne tipy na stiahnutie tu:

GR Σημαντικές συμβουλές συναρμολόγησης για λήψη εδώ:

BG Важни съвети за сглобяване, които да изтеглите от тук:

LT Svarbūs surinkimo patarimai, kuriuos galite atsisiųsti čia:

RO Sfaturi importante de asamblare pentru descărcare aici:

LV Svarīgi montāžas padomi, ko lejupielādēt šeit:

HR Ovdje možete preuzeti važne savjete za montažu:

LU Wichtig Assemblée Tipps fir hei erofzelueden:

DK Vigtige monterings tips til download her:

ARB صائح مهمة حول التجميع للتنزيل من هنا:







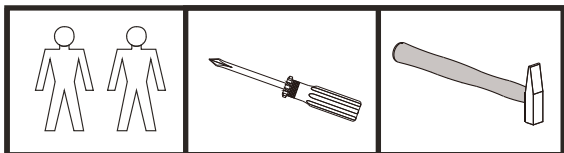
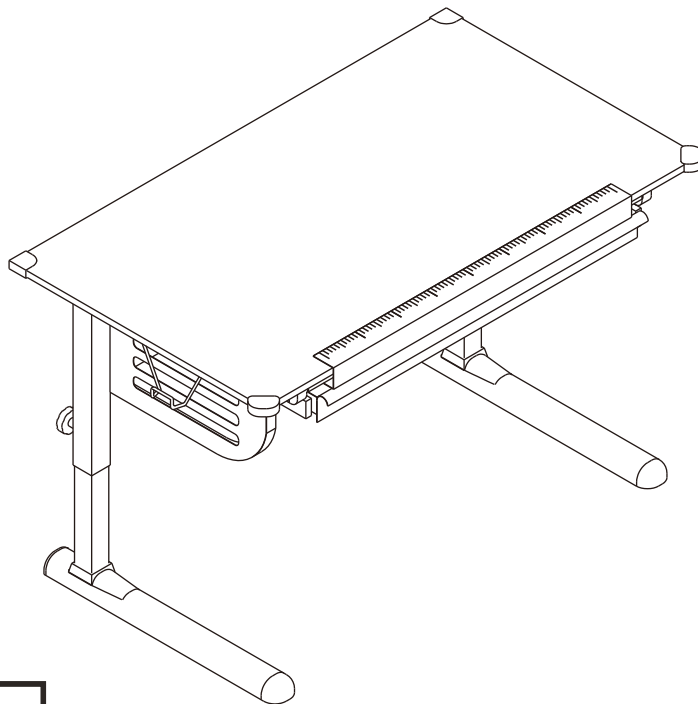



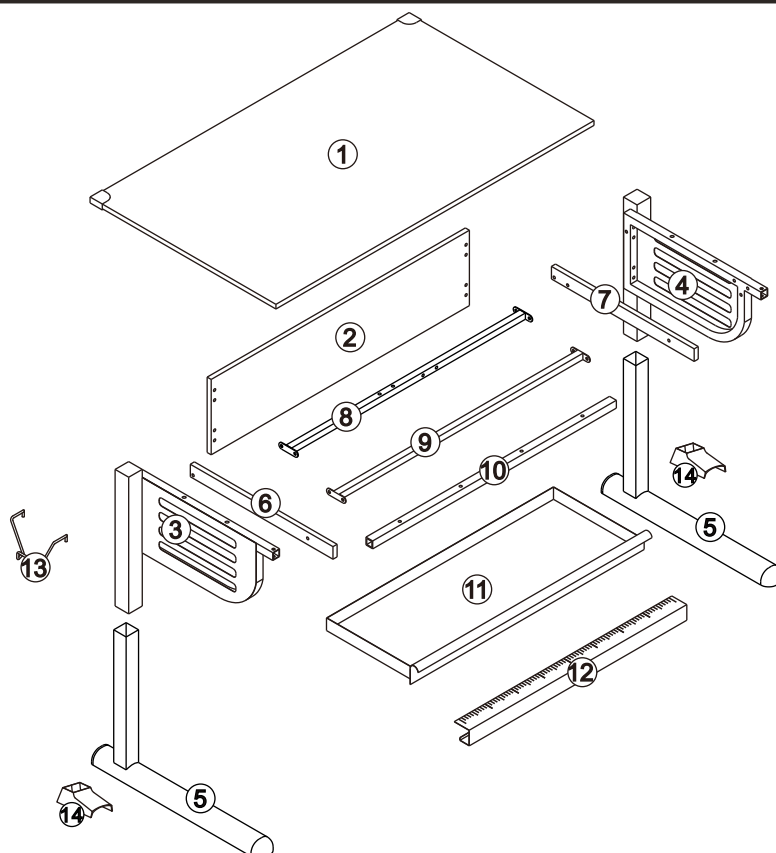

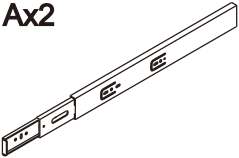
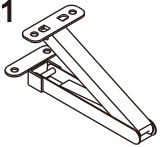
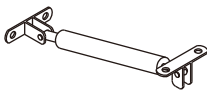

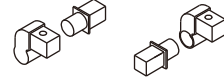

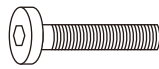

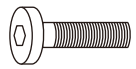
SKALARE

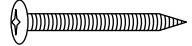
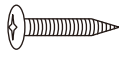
Montage Anleitung / Notice de Montage / Assembling Instruction



Für den Aufbau werden die hier abgebildeten Werkzeuge benötigt.
Avant le montage, se munir des outlis nécessaires.
For the assembly you need the tools shown above.

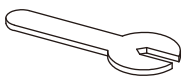

Ax2 	Bx1 	Cx1 	Dx2 	Ex2 
Fx2 	Gx8 	Hx2  6x32mm	Ix2  6x30mm	Jx10  6x28mm
Kx14  6x16mm	Lx4  5x35mm	Mx2  5x14mm	Nx4  4x14mm	Ox4  4x8mm
Px2  M6	Qx4  M4	Rx2 	Sx8 	Tx2 
Ux1  M6				

1

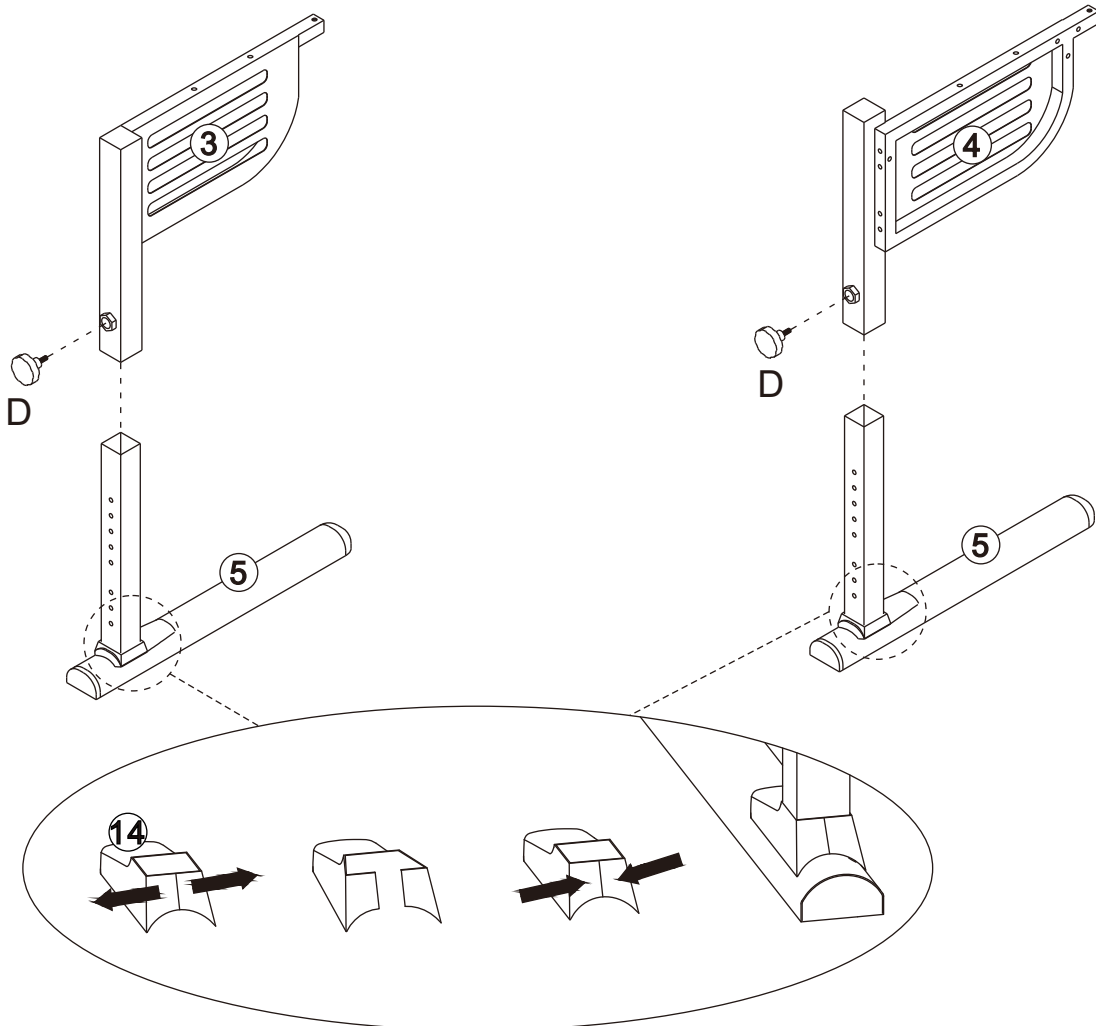

2

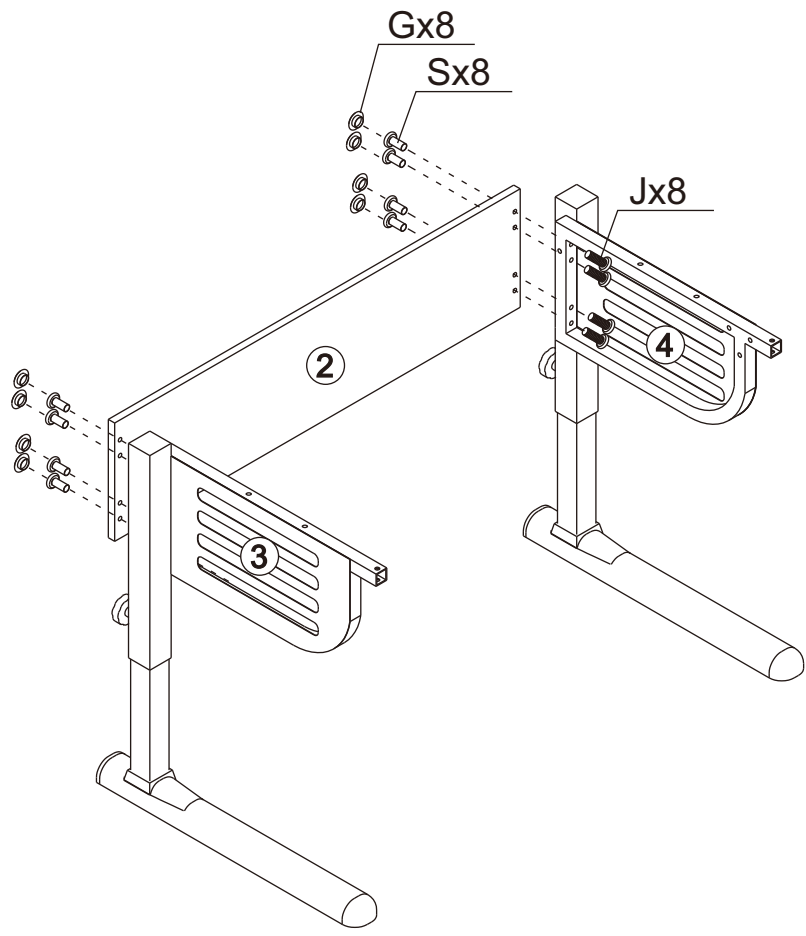

3

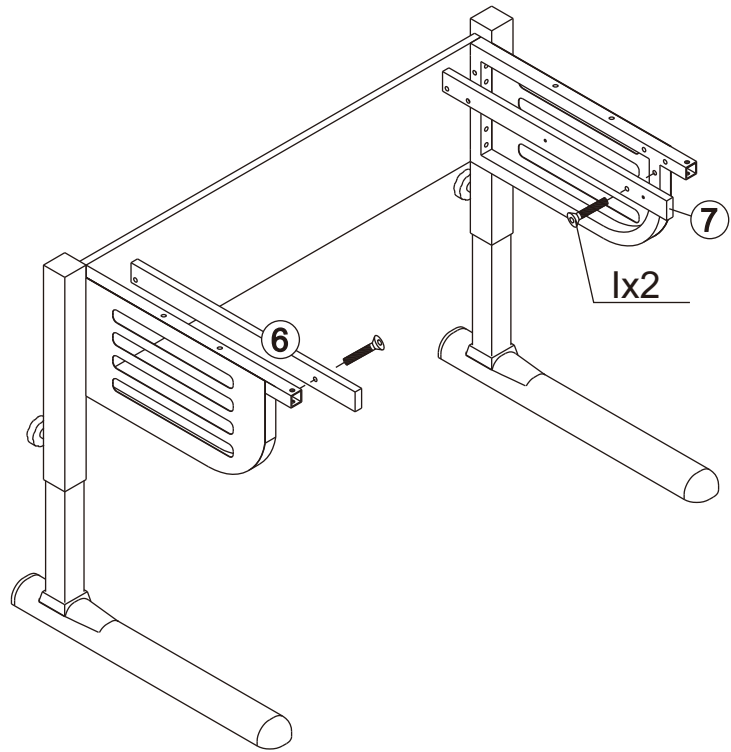

4

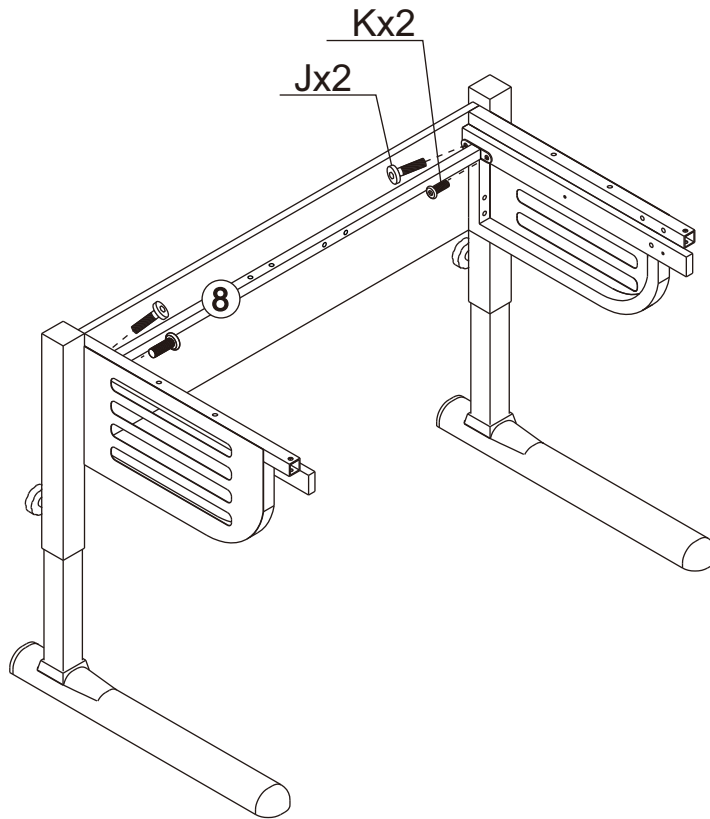

5

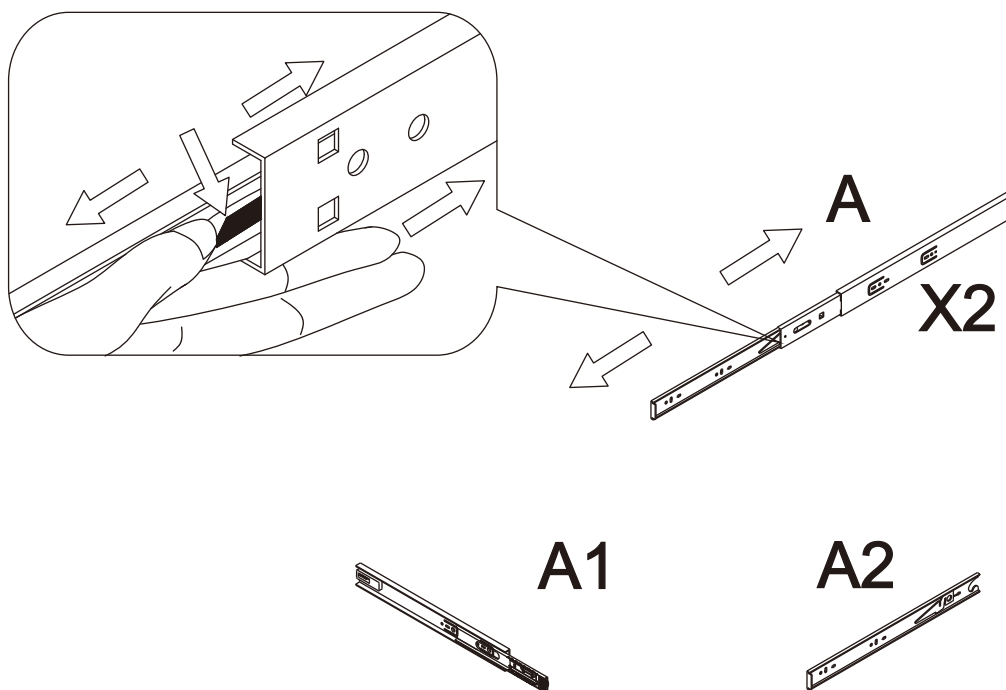

6

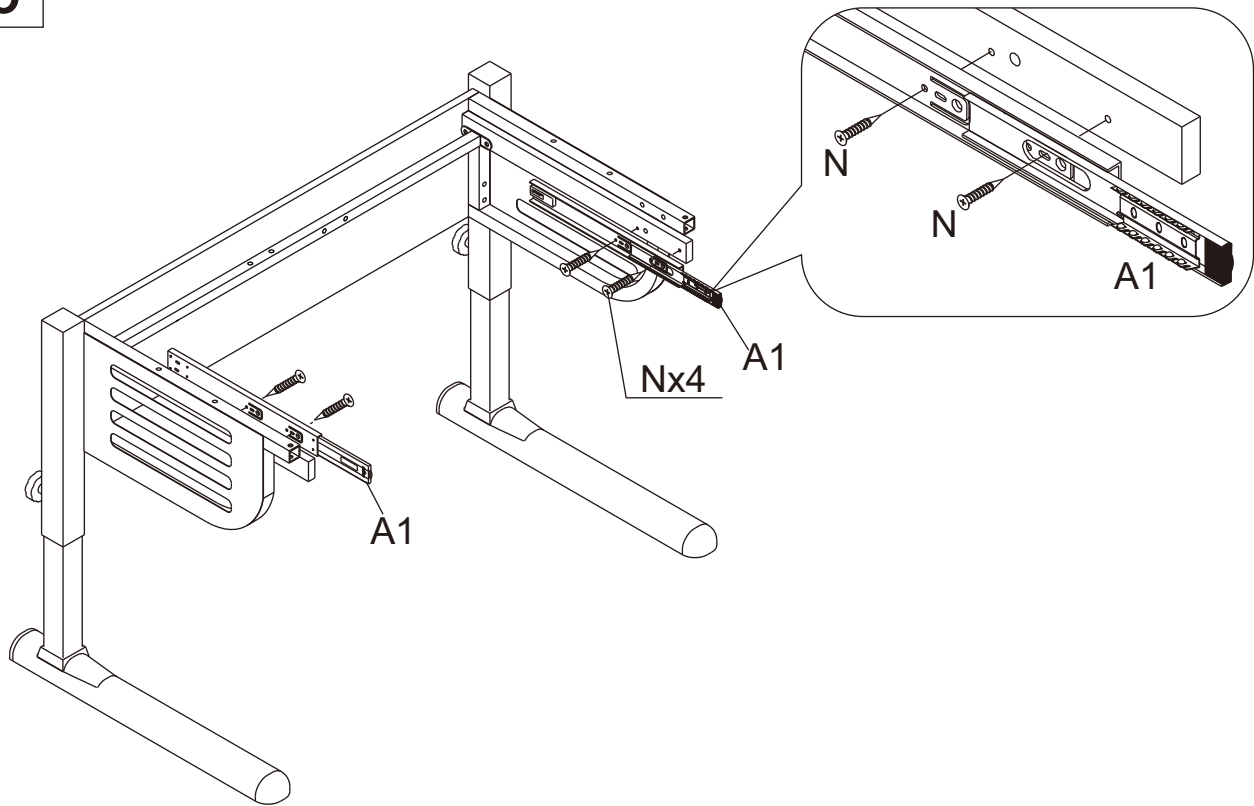

7

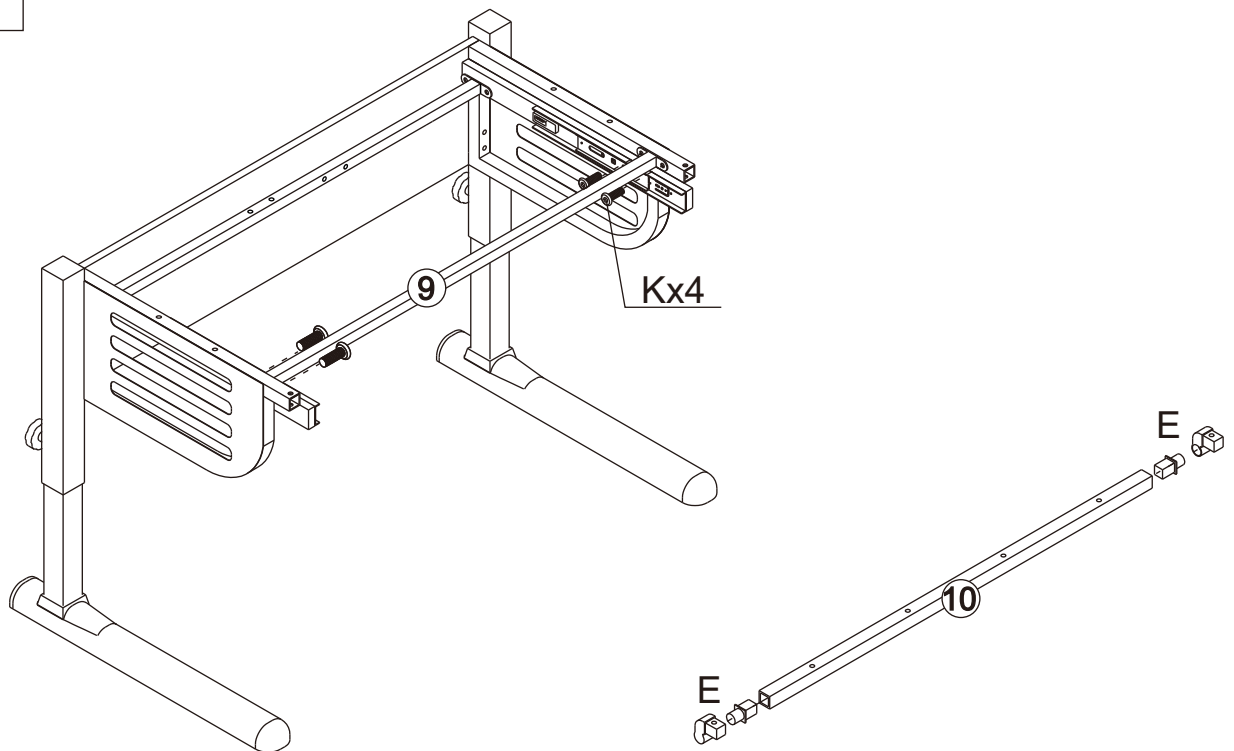

8

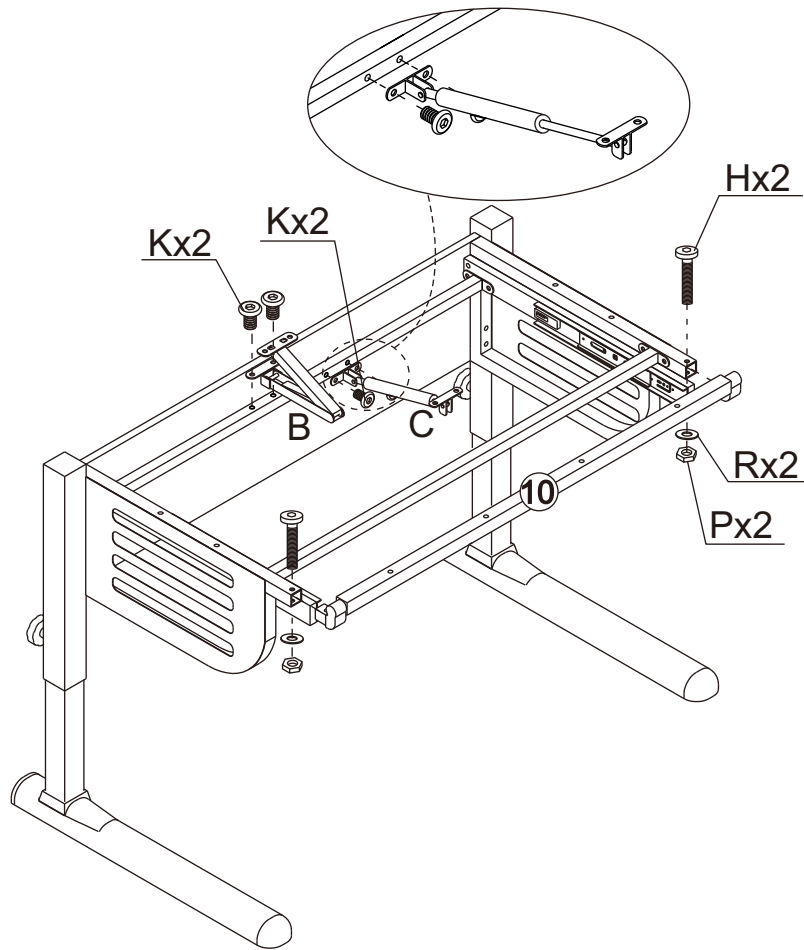

9

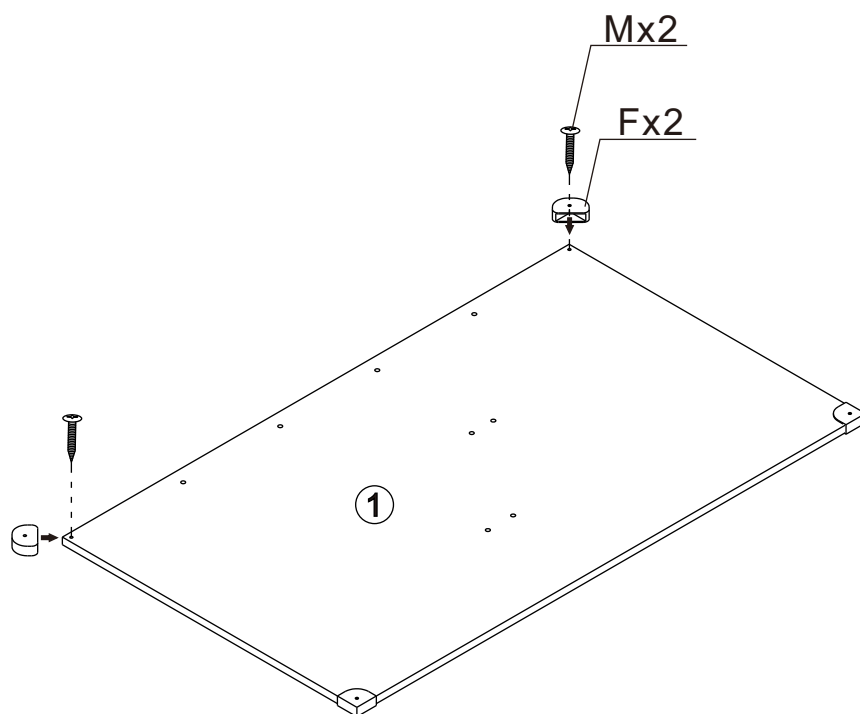

10

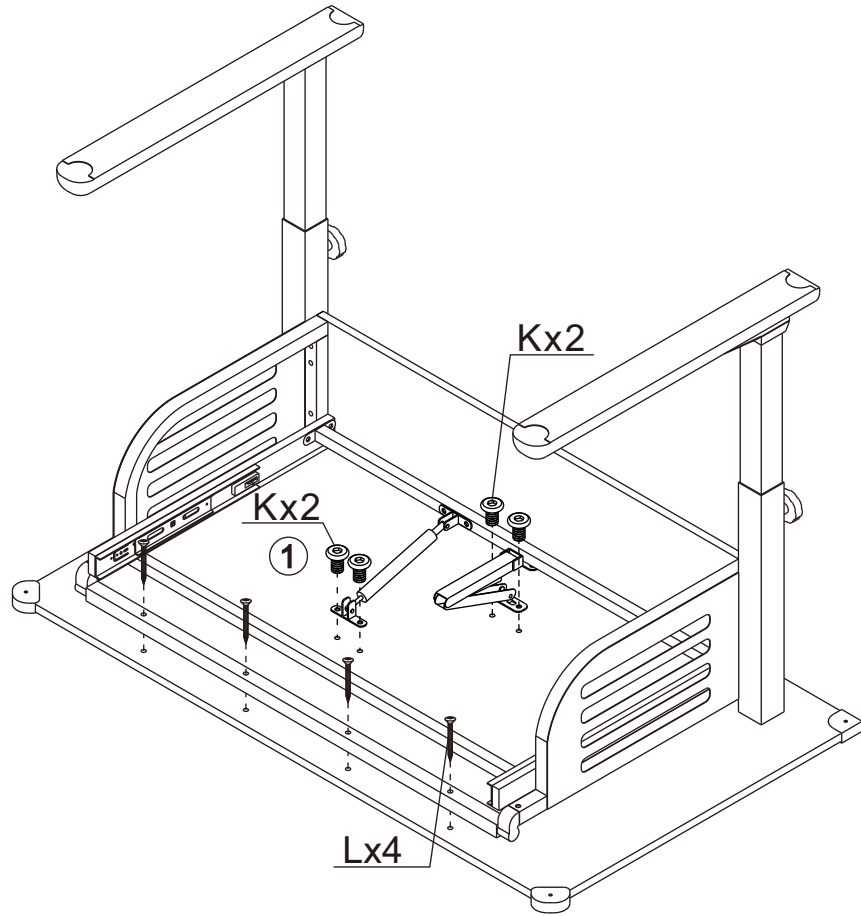

11

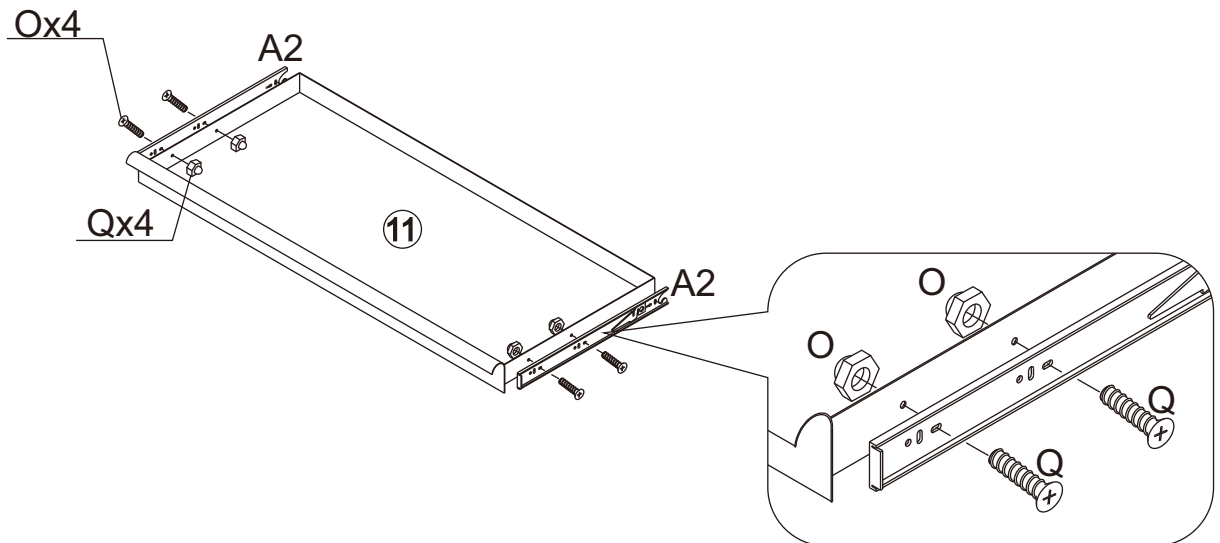

12

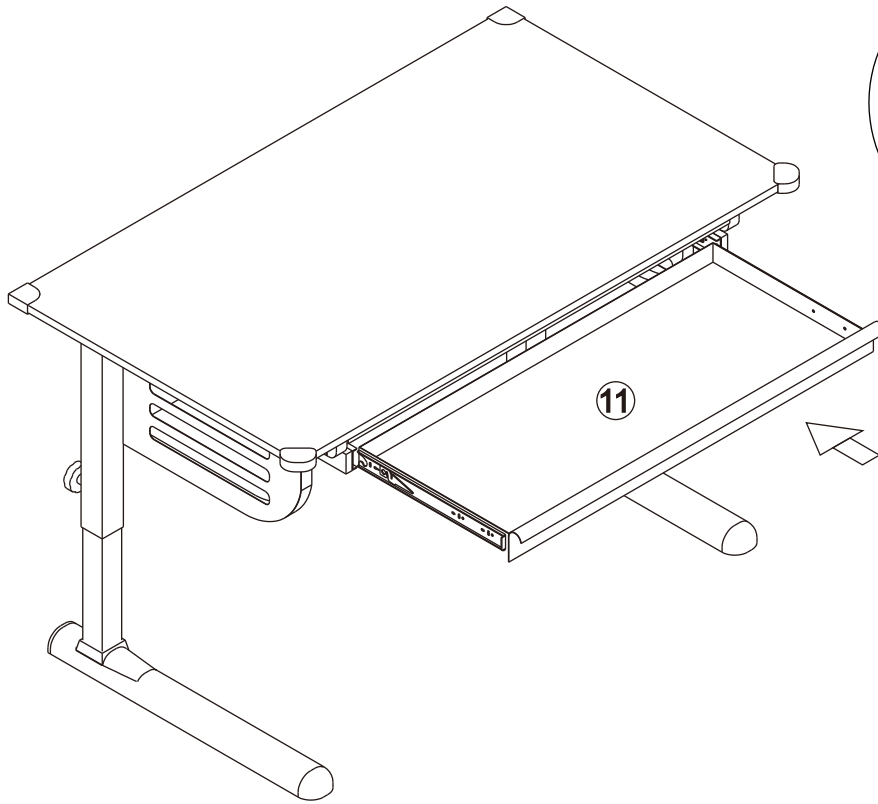

13

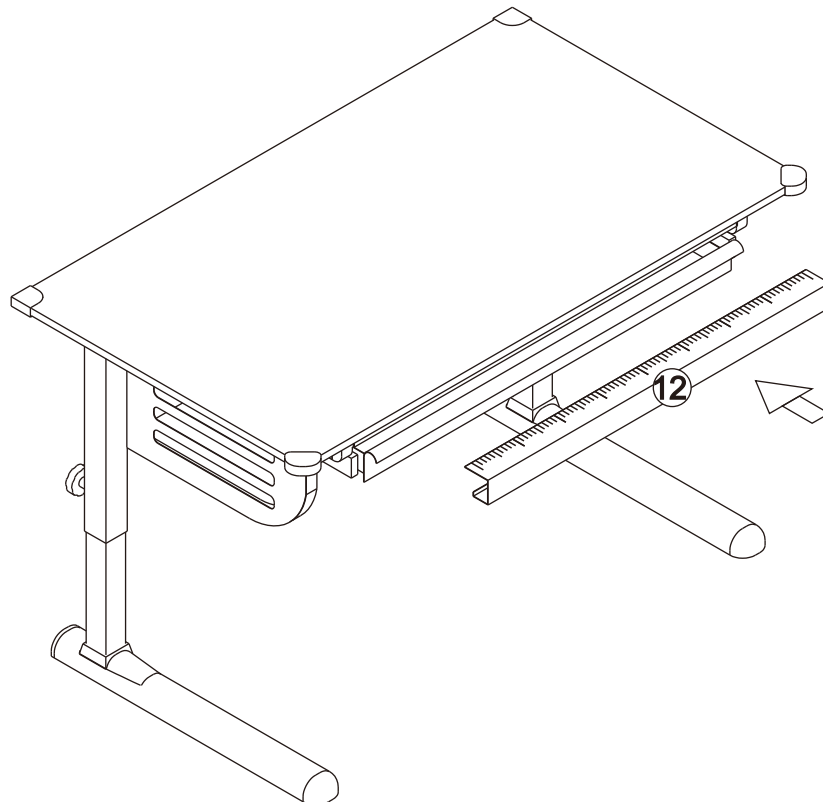

14

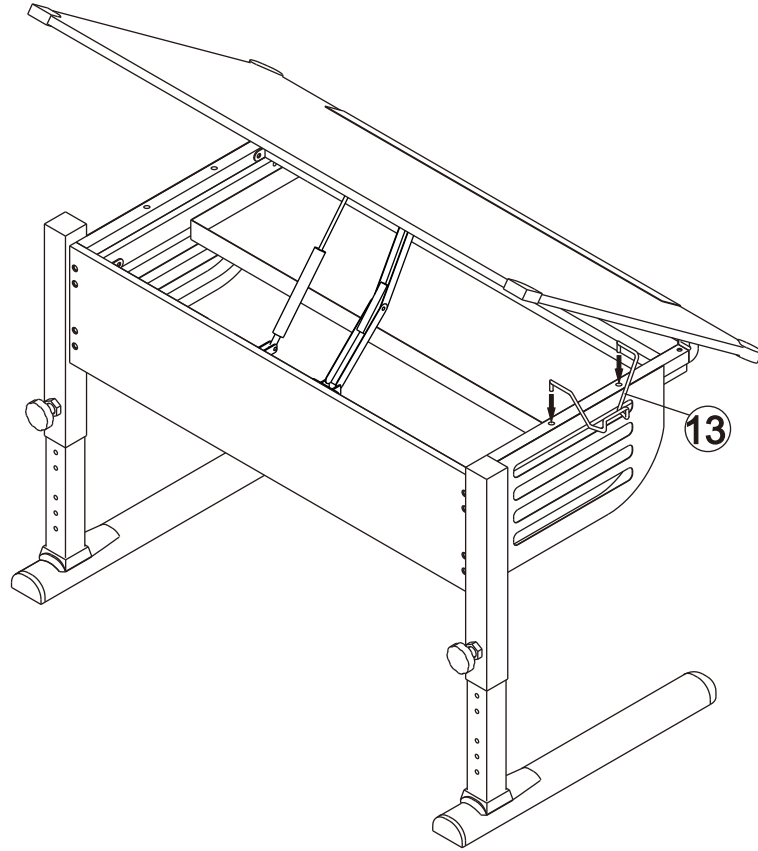

15

