

REPC-Nr.:

Service • Assistenza • Dienstverlening • Serwis  
Servis • Szerviz • Сервисная служба

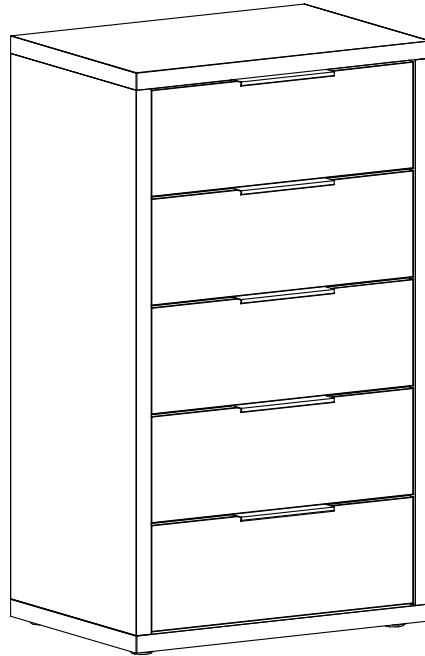

Artikel.-Nr.:

Montageanleitung.-Nr.:

**0801-KO\_05-64**

**MA1-00283**

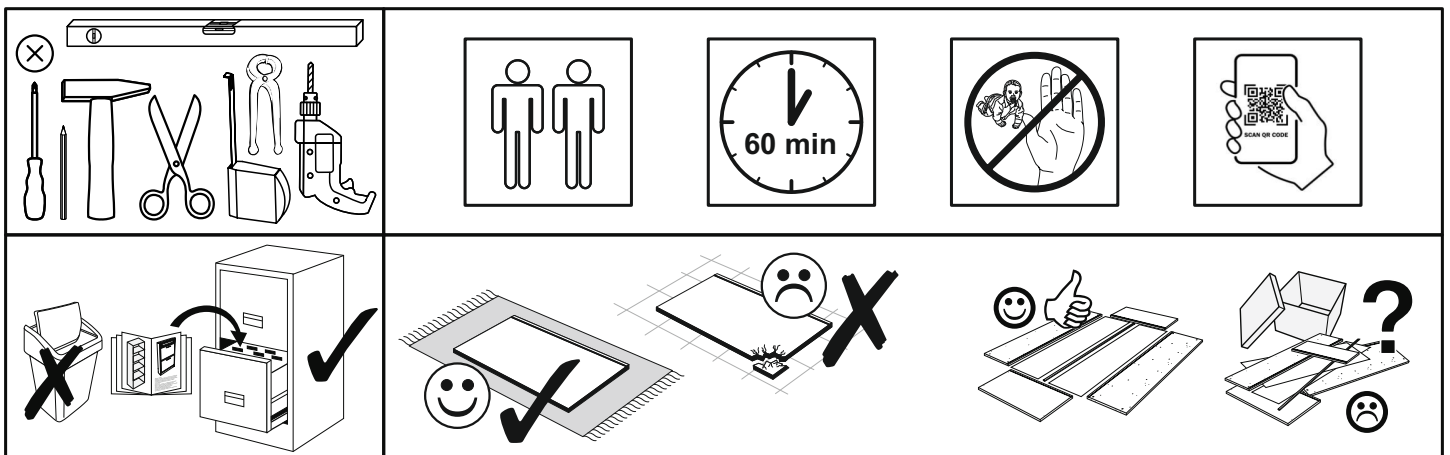

SCAN ME

Das Ersatzteil-Anforderungsformular finden Sie auf  
The replacement parts requisition form you find on  
<https://www.maeusbacher.de/ersatzteile/>

## BT1-00005 Colli 1/2

B01-123		B02-173	
8x	4,0x15	4x	

## BT1-00366 Colli 1/2

B01-20		B01-200		B01-30		B01-90			
4x	7,0x70	30x	6,3x13	30x	3x16	4x	3,5x20		
B02-10		B02-20		B02-103		B05-20		B08-80	
24x	ø15x12mm	24x		40x	8x30	20x		1x	

## BT1-00367 Colli 1/2

B05-185		B06-424	
4x		5x	200mm

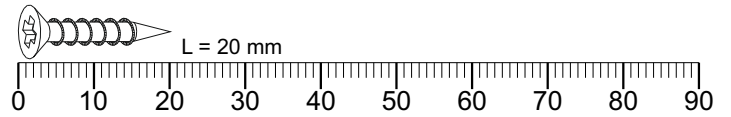

▶ SCAN ME





## Colli 1/2

 564 x 199	 500x50mm	 536 x 358		
 555 x 124	 335 x 124			

## Colli 2/2

 633 x 444	 1019 x 444
 633 x 444	 1019 x 444
 1031 x 290	

**1**

B02-10		B02-20		B02-103		B01-30	
20x	ø15x12mm	20x		40x	8x30	30x	3x16

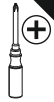

**1**

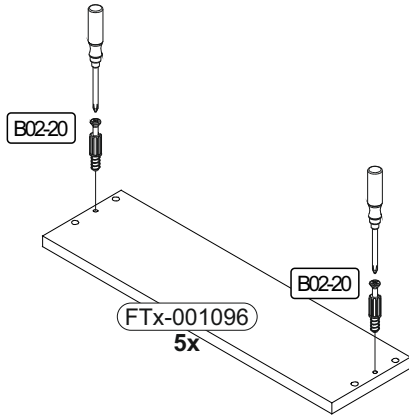

**2**

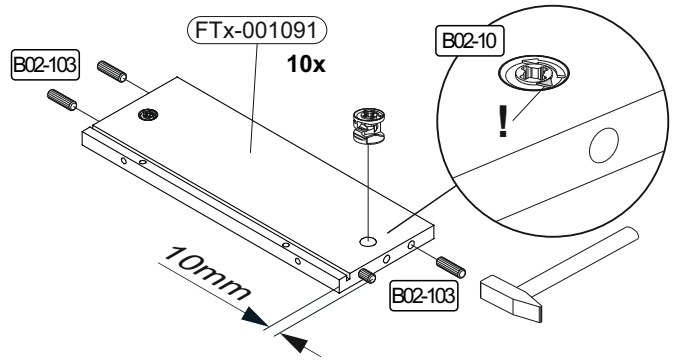

**3**

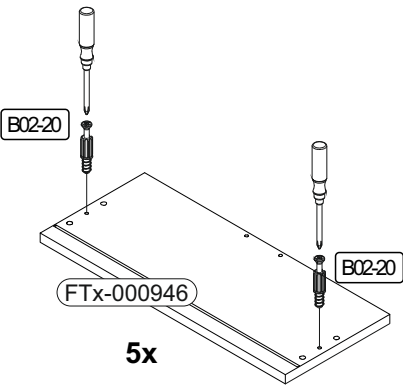

**4**

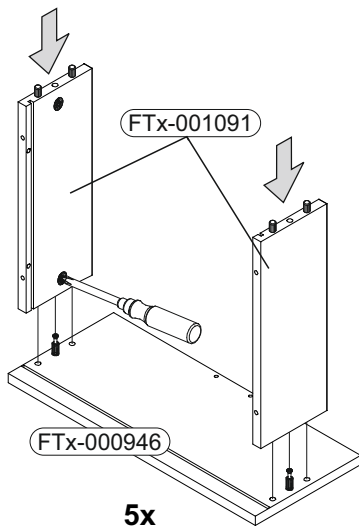

**5**

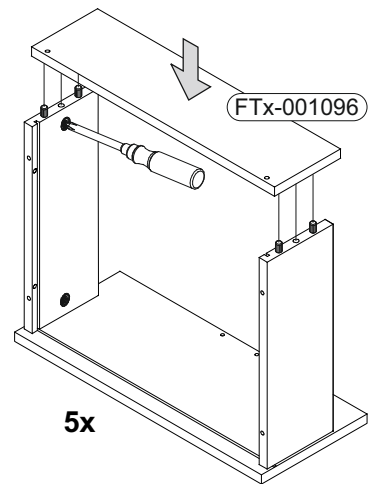

**6**

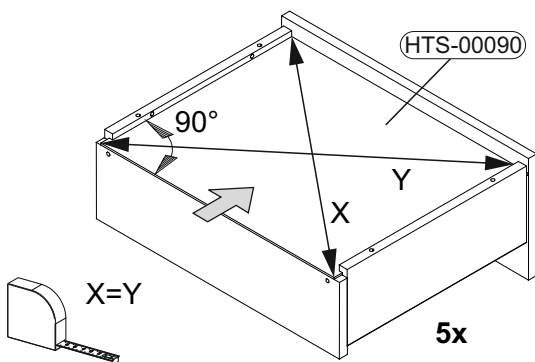

**7**

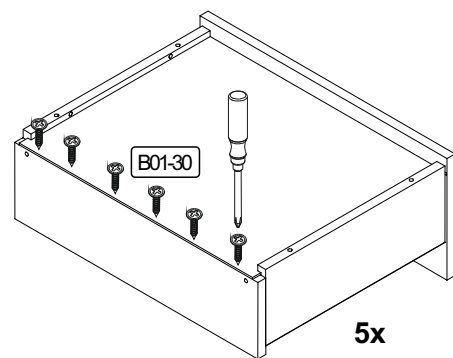

<b>2</b>	B01-200		B06-424		B05-20	
	10x	6,3x13	5x	200mm	20x	

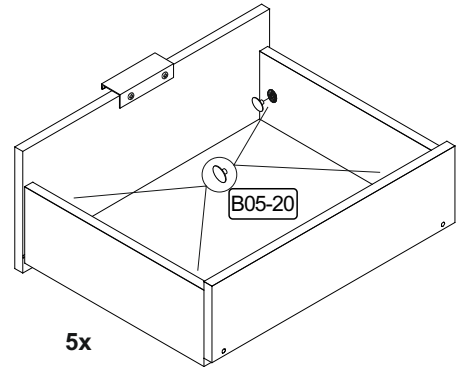
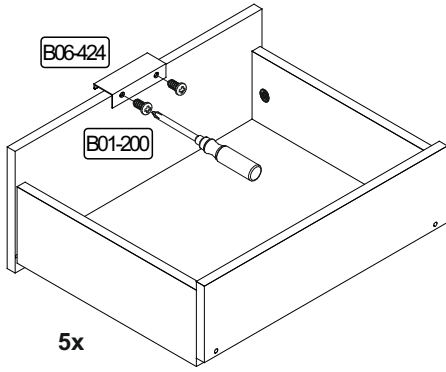
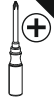

<b>3</b>	B02-20	
	4x	

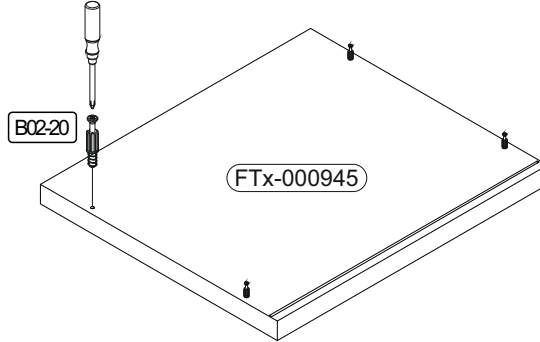
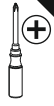

<b>4</b>	B01-200		B02-10		
	20x	6,3x13	4x	ø15x12mm	

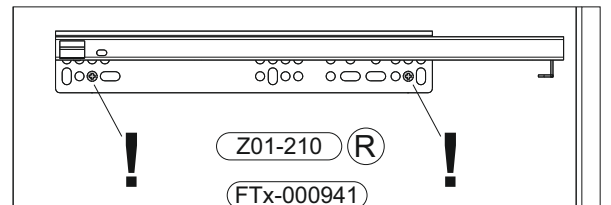
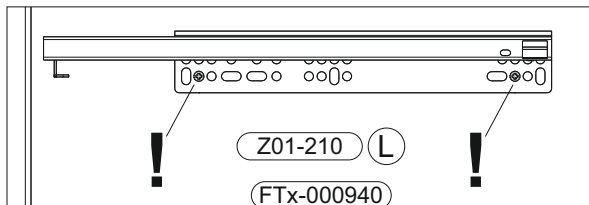
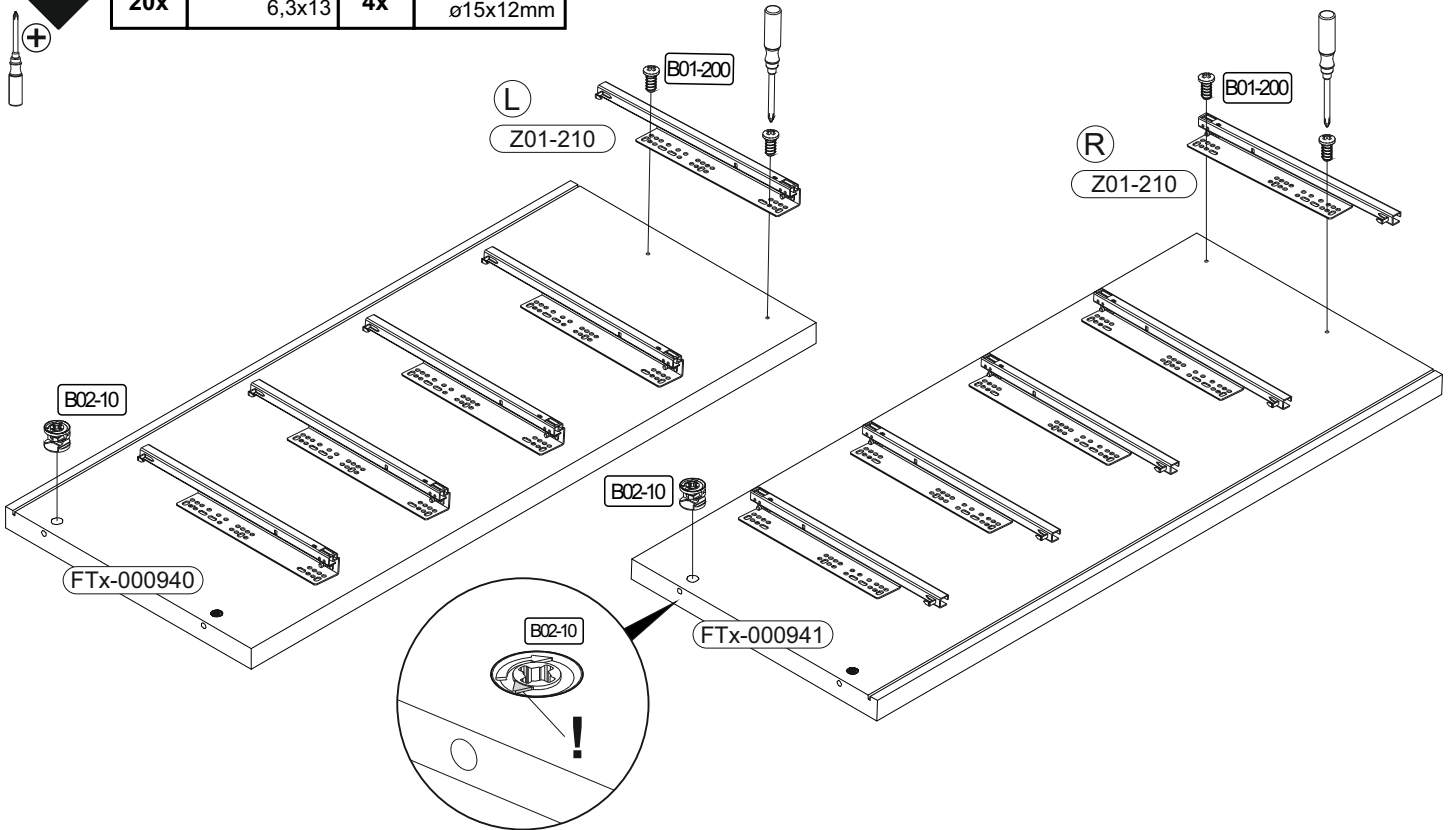
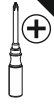

**5**

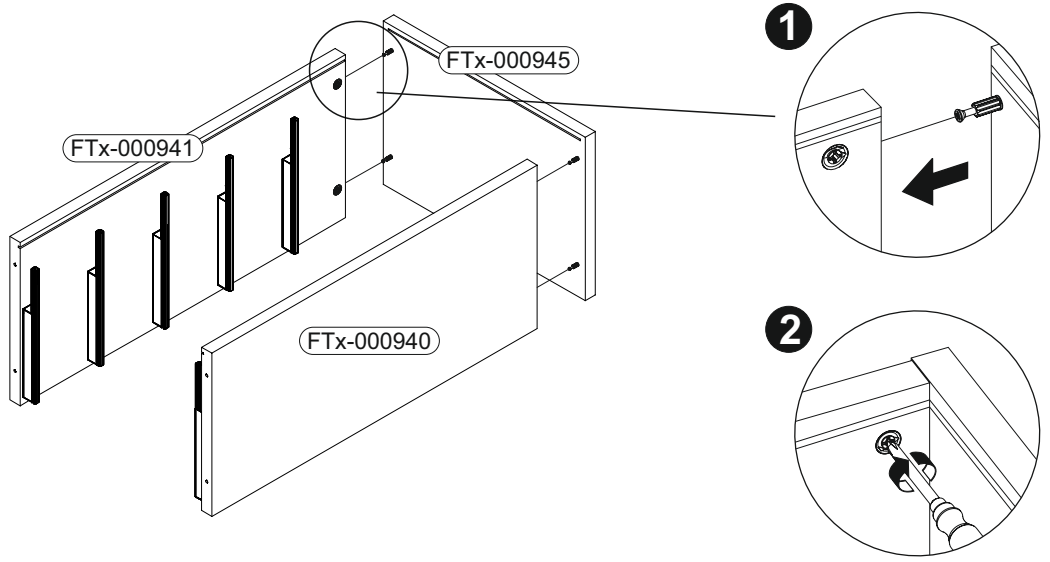

**6**

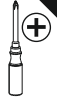

B01-20		B05-185		B01-90	
4x	7,0x70	4x		4x	3,5x20

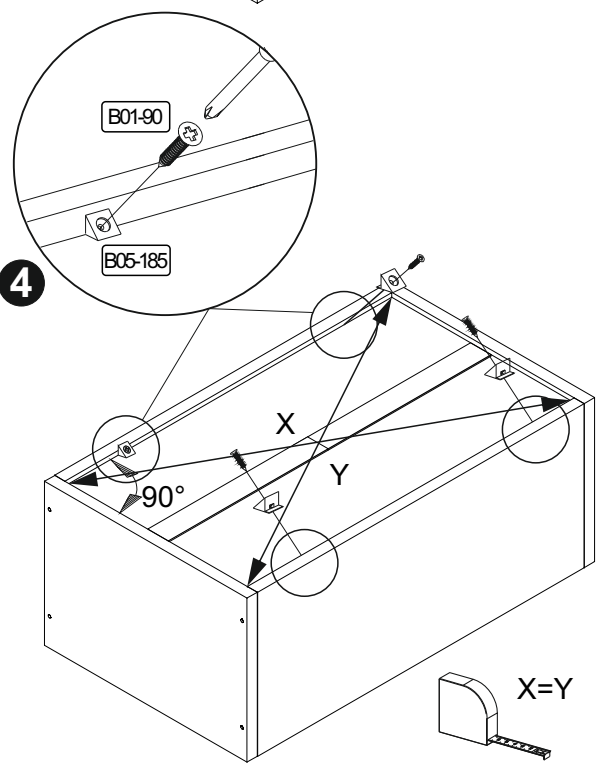
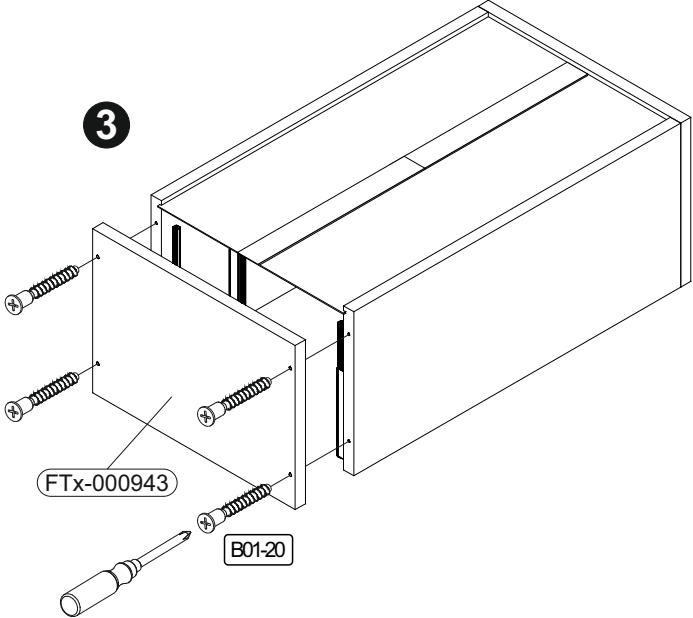
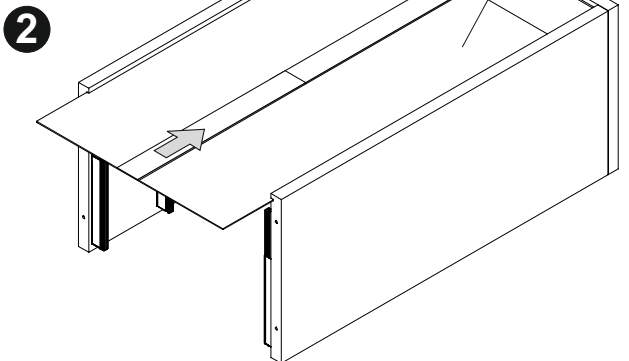
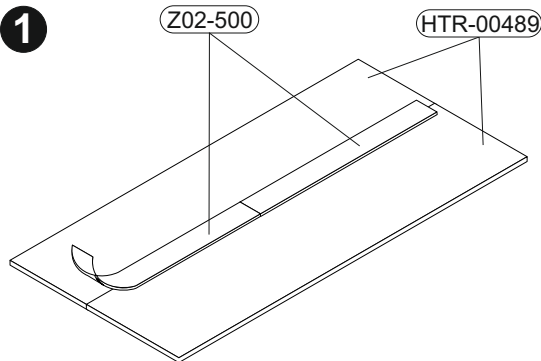

7

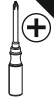

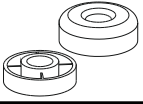
B01-123		B02-173	
8x	4,0x15	4x	

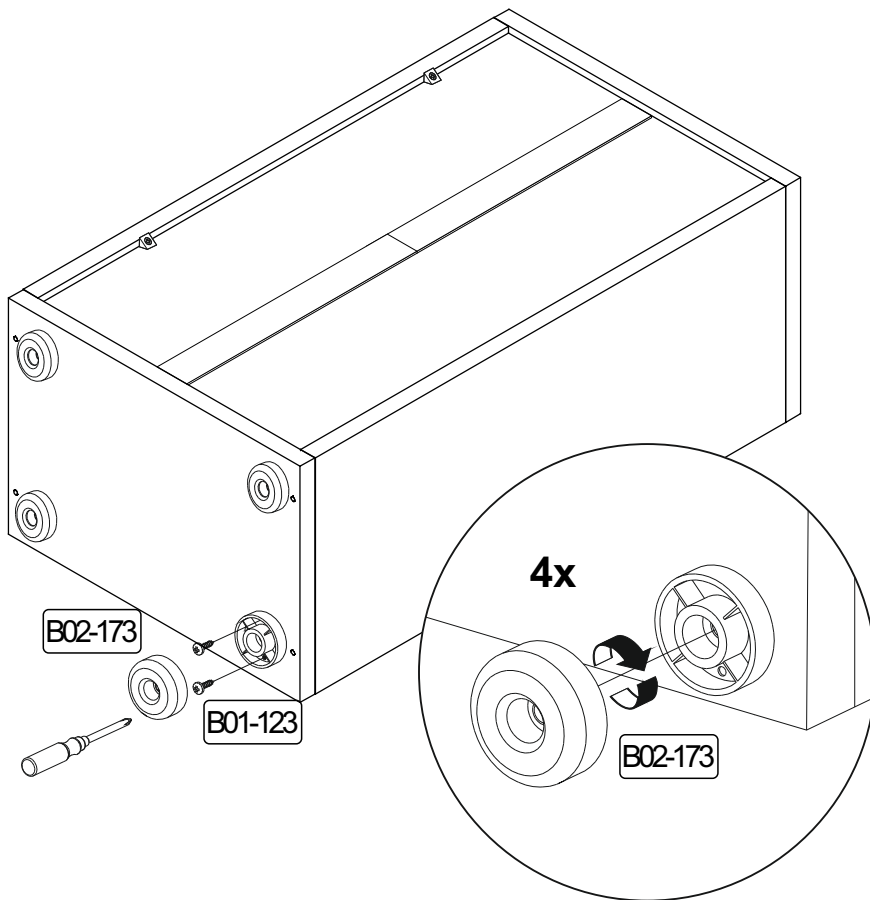
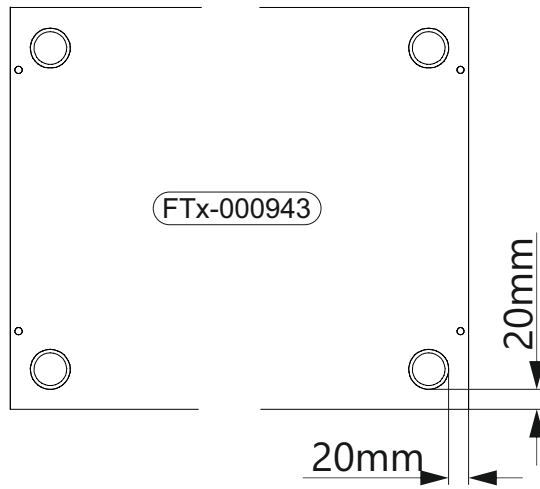



▶ SCAN ME

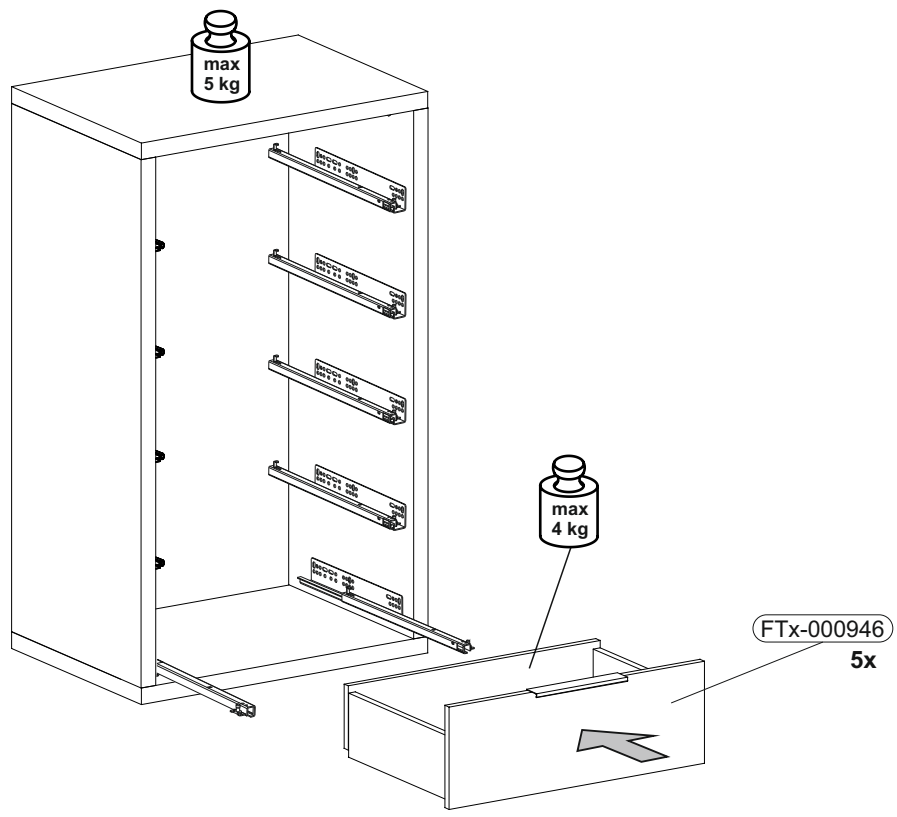

**1**

Z01-210 L

Z01-210 R

Die Stellräder, die der Höhenverstellung dienen nach ganz unten drehen

Pins zur Entriegelung ein Stück weit herausziehen

**2**

Höhenverstellung des Schubkastens

**3**

**Nach** dem Einsetzen und Einstellen der Schubkästen Pins zur Verriegelung eindrücken!

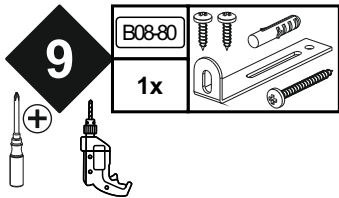

▶ SCAN ME

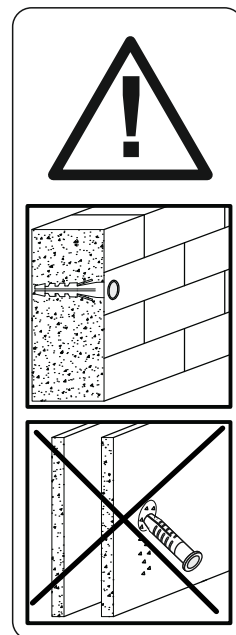
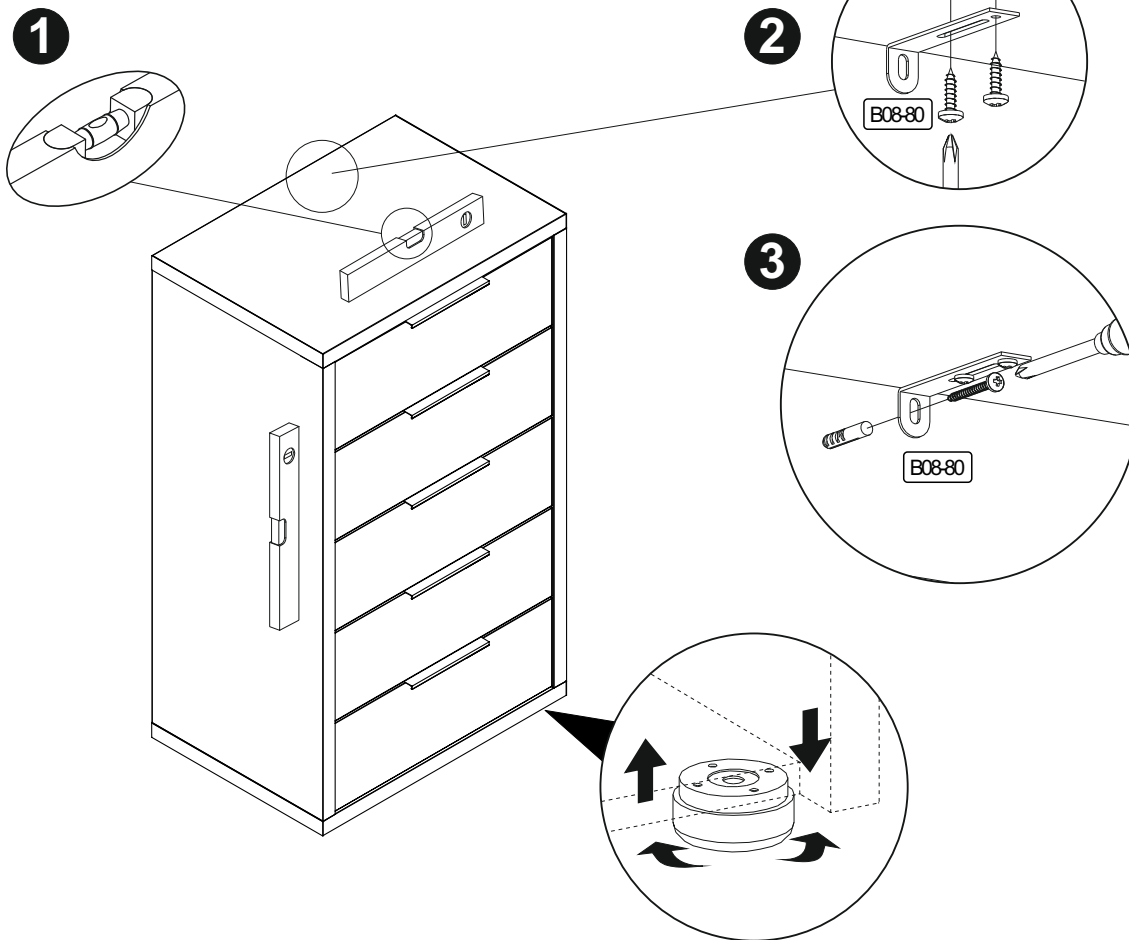

<b>Achtung • Attention • Attenzione • Opgelet • Uwaga • Pozor • Figyelem • Atenție • Dikkat • Внимание</b>	
(D)	Wandbefestigung dient als Kippschutz - unbedingt anbringen! Bei einigen Wandtypen kann ein Spezialdübel erforderlich sein!
(GB)	The wall fastening serves to prevent tipping - be absolutely sure to mount it! For certain wall types, a special wall plug may be necessary!
(FR)	La fixation murale sert de protection contre le basculement – à installer impérativement ! Pour certains types de murs il faut des chevilles spéciales !
(TR)	Duvardaki sabitleme, devrilmeye karşı bir emniyet tedbiridir ve mutlaka monte edilmelidir! Bazı duvar tiplerinde bunun için özel bir dübel gerekli olabilir!
(IT)	Il fissaggio alla parete serve da protezione anti-ribaltamento – attaccarla assolutamente! Per alcune strutture di parete può essere necessario un tassello speciale!
(NL)	Bevestiging aan de muur dient als kantelbescherming – zeker en vast bevestigen! Bij enkele muurtypes is een speciale plug misschien vereist!
(RU)	Обязательно установите крепление на стене во избежание опрокидывания! Для некоторых типов стен может потребоваться специальный дюбель!
(CZ)	Montáž na stěnu slouží jako ochrana proti převrnutí – bezpodmínečně umístěte! U některých typů stěn může být zapotřebí speciální hmoždinka!
(HU)	A terméket a falhoz kel rögzíteni, különben az felborulhat! Egyes faltípusoknál speciális tiplik kell használni!
(RO)	Sistemul de fixare la perete servește ca protecție la răsturnare - de montat obligatoriu! Pentru unele tipuri de pereți este posibil să fie necesar un diblu special!
(PL)	Mocowanie do ściany jest jednocześnie zabezpieczeniem przed przewróceniem – koniecznie zamontować! Do niektórych rodzajów ścian konieczne zastosować specjalne kołki mocujące.
(SK)	Upevnenie na stenu slúži ako ochrana proti prevráteniu – bezpodmienečne použiť! Pre niektoré druhy stien môže byť potrebná špeciálna hmoždinka!